

**250-9006**  
**08 SUZUKI SX4**  
**AUTOMATIC AND MANUAL TRANSMISSION**  
**CRUISE CONTROL INSTALLATION INSTRUCTIONS**

**SERVICE PART NUMBERS**

<b>ITEM</b>	<b>QTY</b>	<b>DESCRIPTION</b>	<b>PART NUMBER</b>
1	1	CONTROL MODULE	250-2736
2	1	MAIN HARNESS	250-2712
3	1	ECM HARNESS	250-2737
4	1	SWITCH	250-2721
5	1	SACK PARTS	250-2738
6	1	BRAKE HARNESS, RED	250-2739
7	1	CLUTCH SWITCH	250-4206

**CONTENTS**

<b>INSTALLATION</b>	<b>2</b>
<b>CONTROL SWITCH</b>	<b>4</b>
<b>TROUBLESHOOTING</b>	<b>5</b>

# INSTALLATION

## A. INSTALLATION PREPARATION:

1. DISCONNECT NEGATIVE BATTERY CABLE BEFORE INSTALLATION. FIGURE 1

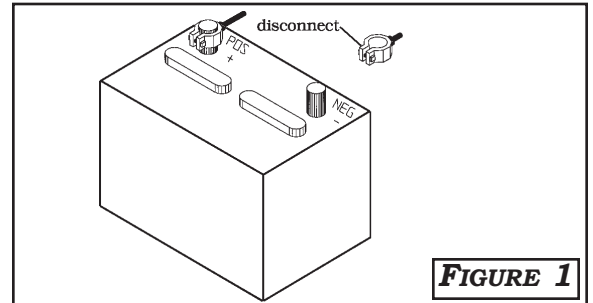

2. REMOVE THE **BOTTOM** CONNECTOR **EO1** OF THE ECM. FIGURE 2

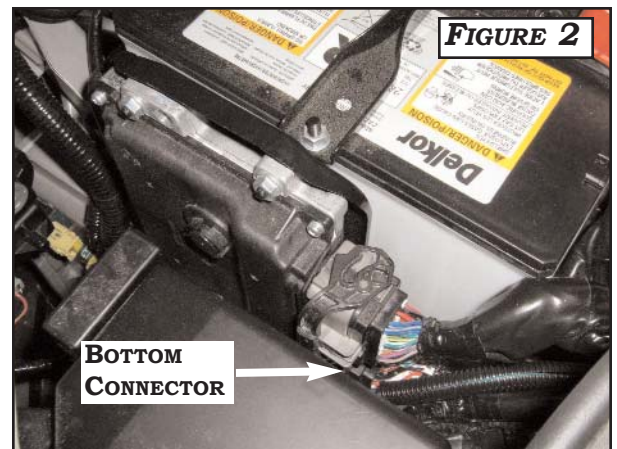

3. USE A PRECISION TOOL OR SMALL SCREWDRIVER TO RELEASE THE RETAINER OF THE CONNECTOR. FIGURE 3. REMOVE THE PLASTIC INSERTS IN PINS 24,8, AND 10.

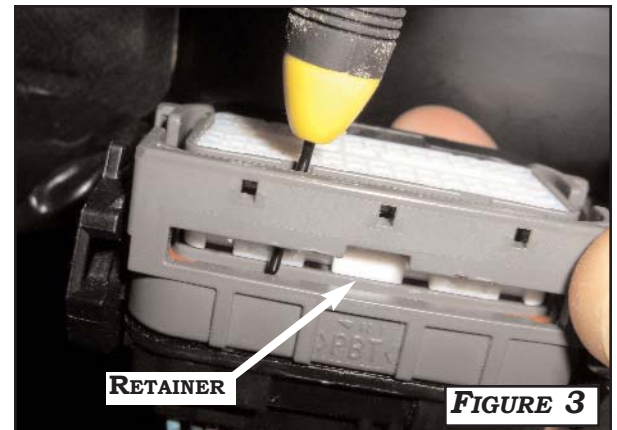

**NOTE: IF POSITIONS 24, 8, AND 10 HAVE THE WIRING PRESENT, USE THE ECM HARNESS SUPPLIED IN KIT TO MATE TO THE EXISTING WIRE IN PINS 24 AND 10 AS STATED BELOW IN THE HARNESS INSTALLATION OF STEP B. THE YELLOW WIRE FROM THE ECM HARNESS IS NOT REQUIRED.**

## B. HARNESS INSTALLATION:

1. LOCATE THE THREE WIRE ECM HARNESS IN KIT. INSERT THE **GREEN** WIRE OF ECM HARNESS IN **PIN 24** OF EO1. INSERT THE **WHITE** WIRE OF ECM HARNESS IN **PIN 10** OF EO1. INSERT THE **YELLOW** WIRE OF ECM HARNESS IN **PIN 8** OF EO1.

**FIGURE 4.** RE-ASSEMBLE CONNECTOR, INCLUDING RETAINER. BE SURE TO PLACE CONNECTOR BACK ON ECM SECURELY.

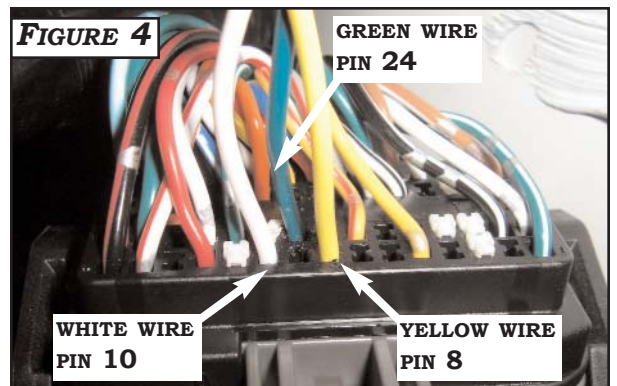

## B. HARNESS INSTALLATION (CONT):

5. REMOVE GLOVE BOX AND ROUTE HARNESS THROUGH ACCESS GROMMET ON PASSENGER SIDE FIREWALL AS SHOWN IN **FIGURE 5**. CONTINUE ROUTING HARNESS TO DRIVER SIDE.
6. REMOVE THE STEERING COLUMN SHROUD, LOWER DASH AND KICK PANELS. **FIGURE 6**
7. LOCATE BRAKE SWITCH. **IF WIRES ARE PRESENT IN PINS 1- 4, THIS STEP IS NOT REQUIRED.** REMOVE THE CONNECTOR AND RELEASE THE RETAINER. **FIGURE 7.** LOCATE THE **RED BRAKE HARNESS** IN KIT. INSERT THE TERMINAL FROM THE RED BRAKE HARNESS TO PIN **4** OF THE BRAKE SWITCH CONNECTOR. INSERT THE TERMINAL FROM THE **YELLOW WIRE** IN THE ECM HARNESS TO PIN **3** OF THE BRAKE SWITCH. **FIGURE 8.** RE-ASSEMBLE CONNECTOR, INCLUDING RETAINER.
8. **FOR MANUAL TRANSMISSION SX4 ONLY:** CUT WIRE IN **PIN 3** OF BRAKE SWITCH AND USE THE **250-4206 CLUTCH SWITCH** TO WIRE IN SERIES.
9. CONNECT THE **GREEN WIRE** FROM ECM HARNESS TO **GREEN WIRE** MARKED **CRUISE 2** OF THE MAIN CRUISE HARNESS.
10. CONNECT THE **WHITE WIRE** FROM ECM HARNESS TO **WHITE WIRE** MARKED **CRUISE 1** OF THE MAIN CRUISE HARNESS.
11. CONNECT THE TERMINAL END FROM THE RED BRAKE HARNESS (IF APPLICABLE) AND THE **RED WIRE** FROM THE MAIN CRUISE HARNESS TO THE **YELLOW/BLUE WIRE** (12V IGNITION) AT FUSE PANEL. FOR REFERENCE, THIS WIRE IS LOCATED ABOVE A BLACK/RED WIRE. **FIGURE 9**
12. CONNECT **BLACK WIRE** OF MAIN CRUISE HARNESS TO **BLACK/ORANGE GROUND WIRE** BEHIND THE DRIVER SIDE KICK PANEL AT THE VEHICLE GROUND POINT. **FIGURE 10.**

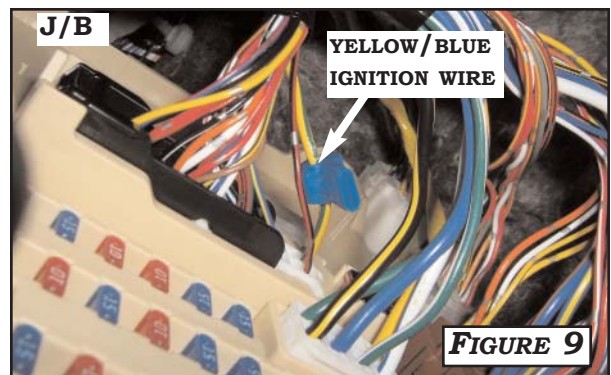
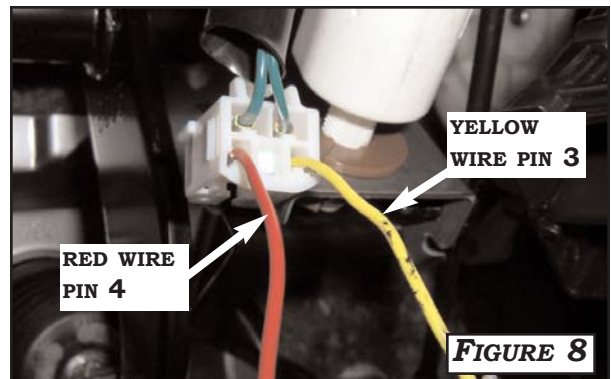
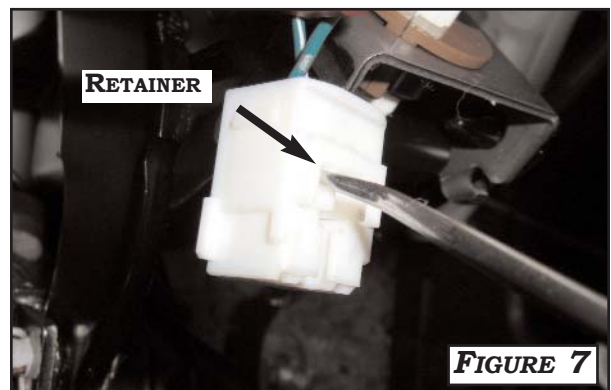
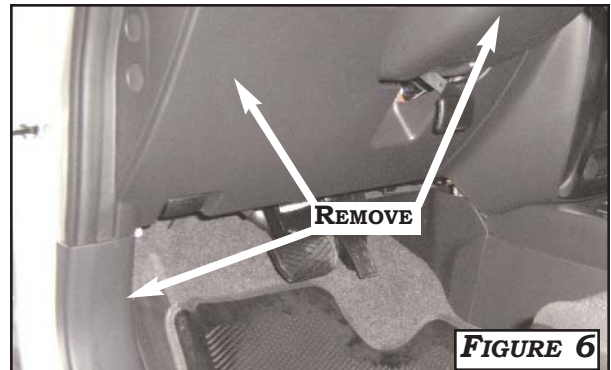

### C. SWITCH INSTALLATION:

1. MARK HOLE AS SHOWN IN **FIGURE 10**. USE THE **LEVER WEDGE** AS AN ANGLE TEMPLATE TO DRILL **9.5MM OR 3/8"** HOLE IN LOWER SHROUD. POSITION THE LOCK WASHERS AS SHOWN IN **FIGURE 11**. START NUT AND POSITION THE LETTERING FOR DRIVER'S BEST VIEW. FULLY SECURE NUT AT **2.5-2.8Nm**. **Do Not Overtighten**.
2. LOCATE THE 4 PIN CONNECTOR CONNECTOR IN HARDWARE KIT. **FIGURE 12** INSTALL 4 PIN CONNECTOR ON **RED, BROWN, GREEN, AND YELLOW** SWITCH WIRES. **Do NOT USE THE BLACK AND BLUE SWITCH WIRES**. WRAP WIRES WITH ELECTRICAL TAPE.
3. CONNECT SWITCH HARNESS TO MAIN CRUISE HARNESS. VERIFY THAT ALL COLORS MATCH. CONNECT MAIN CRUISE HARNESS TO CRUISE CONTROL MODULE.

### D. REASSEMBLY:

1. REINSTALL ALL REMOVED PARTS FROM THE VEHICLE.
2. SECURE ALL WIRES WITH WIRE TIES.
3. RECONNECT NEGATIVE BATTERY CABLE.

### E. TESTING:

1. TEST CRUISE FUNCTIONS IN ACCORDANCE WITH OPERATING INSTRUCTIONS. THE "CRUISE" INDICATOR LIGHT WILL ACTIVATE IN THE INSTRUMENT CLUSTER WHEN THE CONTROL SWITCH IS TURNED ON. THE CONTROL SWITCH INDICATOR LIGHT WILL NOT ILLUMINATE FOR THIS APPLICATION.

**IMPORTANT: VERIFY CRUISE DISENGAGES WHEN VEHICLE IS PUT IN NEUTRAL OR BRAKE IS DEPRESSED.**

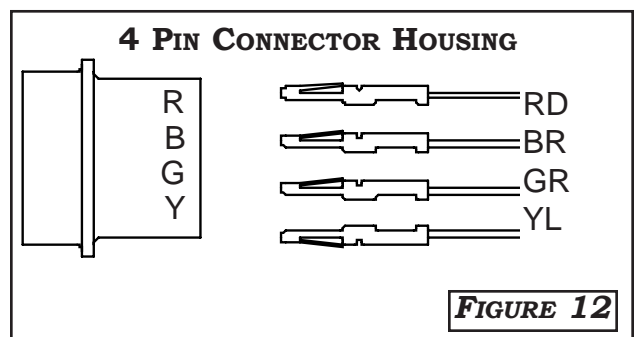
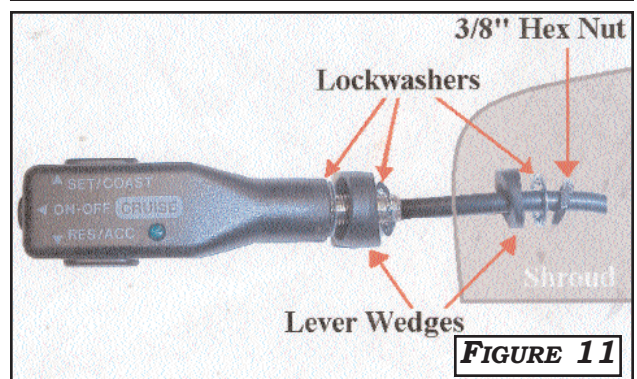
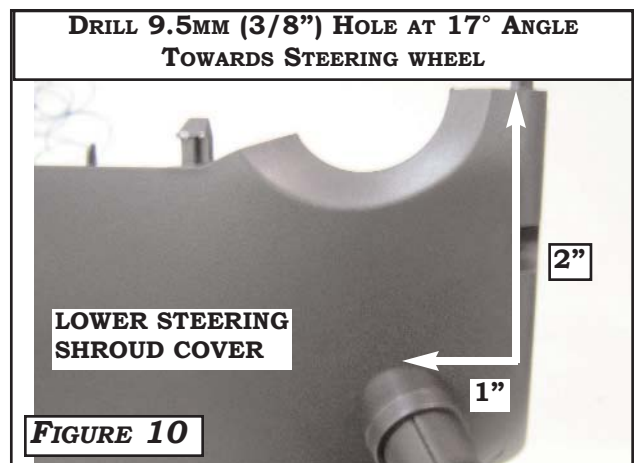
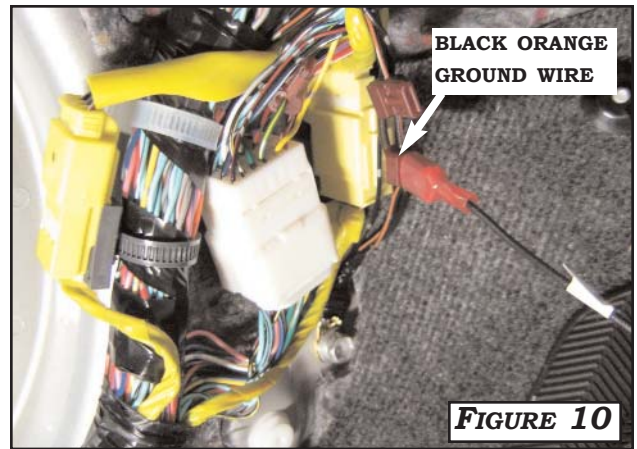

**CAUTION: Do NOT USE THE BLACK AND BLUE WIRES FROM THE CONTROL SWITCH. WRAP WIRES WITH ELECTRICAL TAPE**

# SYSTEM LAYOUT

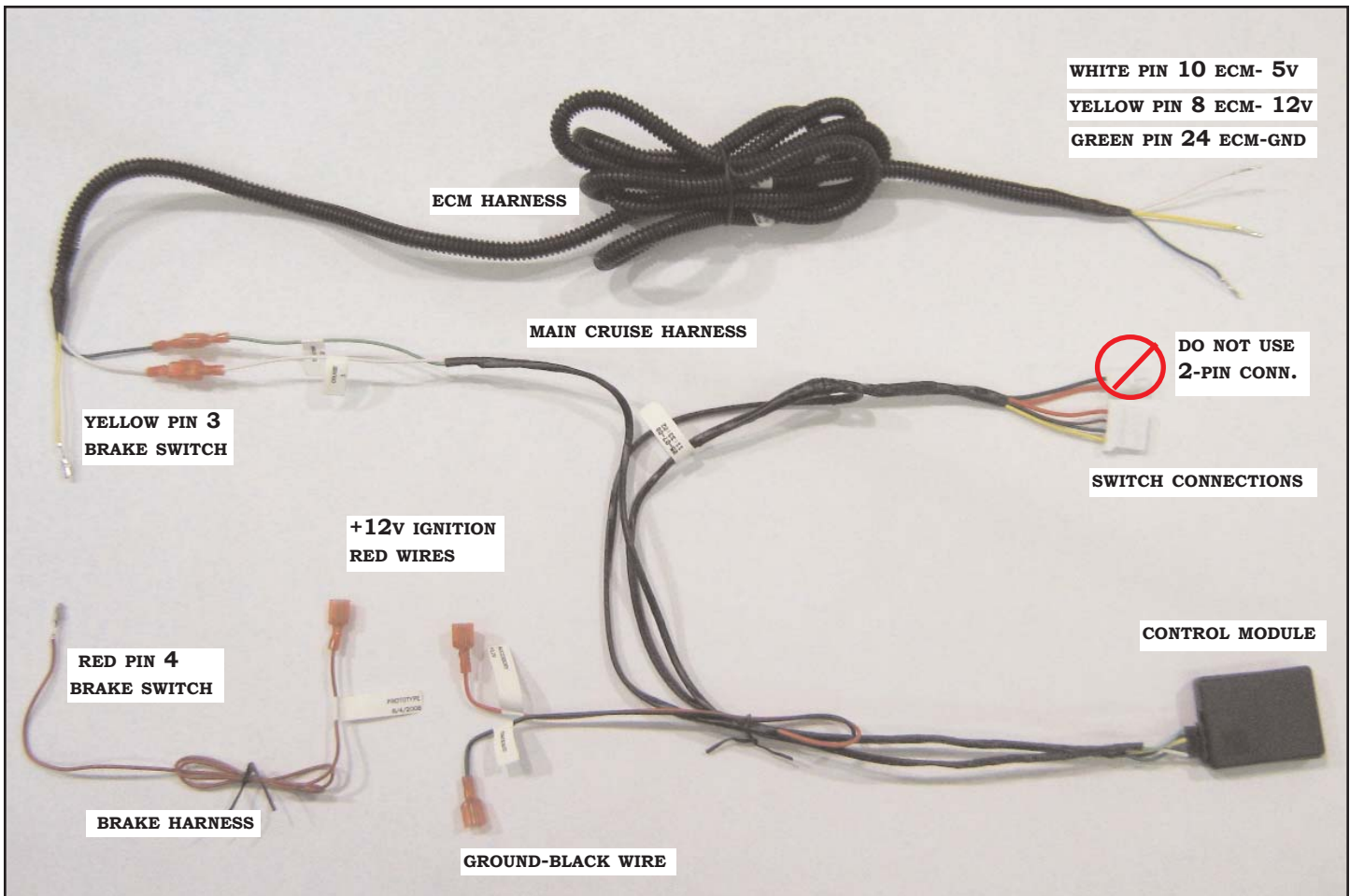

1. Check black and green wires with meter for ground no higher than 3 ohms of resistance.
2. Check Red wire for ignition 12 volts.
3. With everything connected, check White wire voltages at the control module in harness:

Off: 5 volts on White wire from the ECM

On: 0 volts on White wire

On with "Set" pressed: 3 volts on White wire

On with "Resume" pressed: 4 volts on White wire

# NOTES

# NOTES



**ROSTRA.COM**