

General Applicability

All Motors



1-800-343-1382

Please call for technical assistance. You will need your invoice number.

Item #	Qty.	Description
1. 250-2763	1	Cruise Control Module
2. 250-2760	1	Switch Harness
3. 250-2759	1	Main Wiring Harness
4. 250-2766	1	Pedal Interface Harness
5. 250-2767	1	Hardware Kit
6. 250-3742	1	Control Switch

Kit Contents/Service Parts

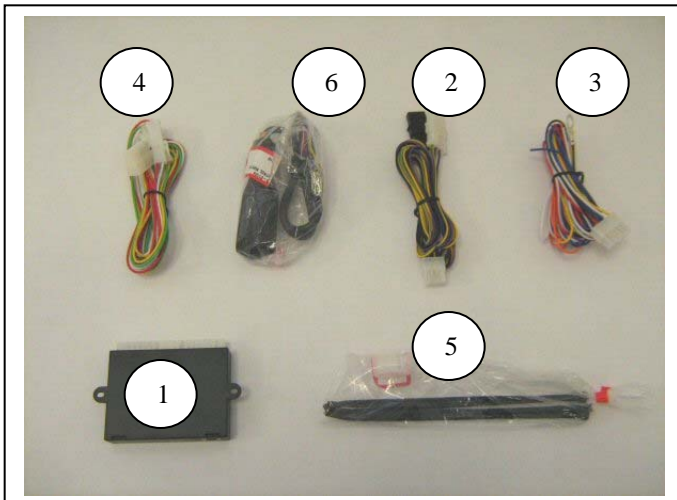

Recommended Sequence of Application





Item #	Accessory	
1		
2		
3		

Contents of Hardware Bag, 250-2763

Qty	Description
8	Wire Zip Ties

Additional Items Required For Installation

Legend

-  **STOP:** Damage to the vehicle may occur. Do not proceed until process has been complied with.
-  **OPERATOR SAFETY:** Use caution to avoid risk of injury
-  **CRITICAL PROCESS:** Proceed with caution to ensure a quality installation.
-  **GENERAL PROCESS:** This highlights specific processes to ensure a quality installation.
-  **TOOLS & EQUIPMENT:** This calls out the specific tools and equipment required for this process





DUE TO SENSITIVE NATURE OF SIGNALS USED FOR THIS PRODUCT ALL CONNECTIONS MUST BE SOLDERED.



FAILURE TO COMPLY WITH THIS REQUIREMENT WILL VOID WARRANTY.

Section I – Installation Procedure

A. Pre-Installation Suggestions

1.  It is advisable to disconnect the negative battery cable for 3 minutes before beginning installation, to avoid unintended air bag deployment. Note and record any anti-theft radio codes prior to disconnecting. **Figure 1**
2.  Remove the driver side lower dash panel. Remove the steering wheel shroud. **Figure 2**

B. Install Electronic Module

1.  Apply the large supplied piece of double-sided adhesive tape to the Cruise Control Module.
2.  Plug in the **Main Wiring Harness, Switch Harness, and Pedal Interface Harness** onto mating connectors of the Cruise Control Module. **Figure 3**
3. Place the **Cruise Control Module** in a secure location behind the driver side dash area near the firewall away from moving parts. Secure with supplied wire ties.
4. Route the **Pedal Interface Harness** through steering column and down to the accelerator.
5. Locate the 6 pin **plug and mate connectors** on the Pedal Interface Harness. Remove the accelerator 6-pin connector and apply to mating connector of Pedal Interface Harness. Apply the other connector to the accelerator. **Figure 4**

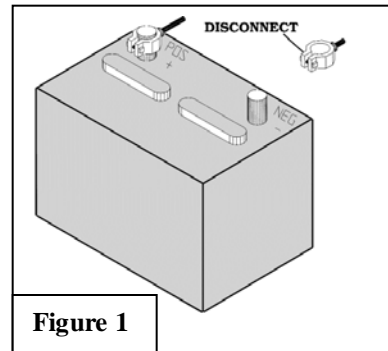

Figure 1

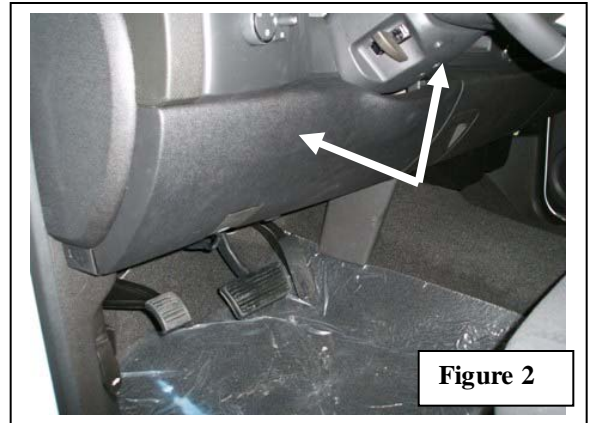

Figure 2

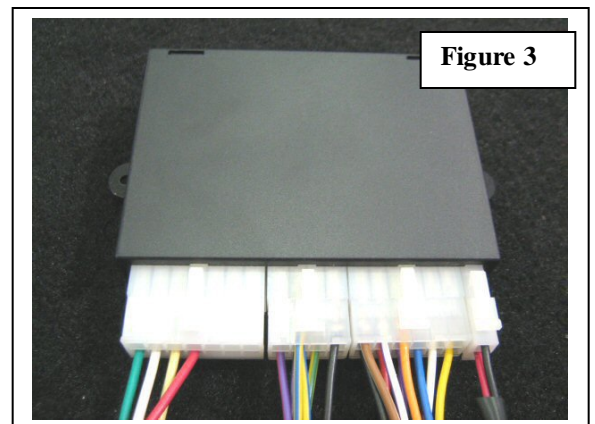

Figure 3

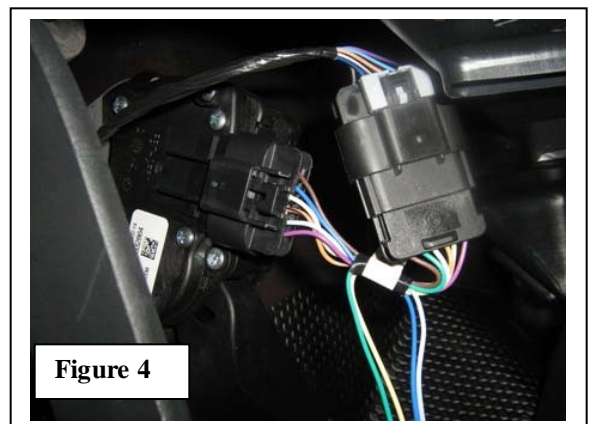
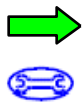

Figure 4

C. Wiring Connections



1. Locate the junction box under the driver-side lower dash area. Solder and connect the following wires from the main harness to the vehicle using diagram below:

Function	Location Figure 6	Cruise Harness Color	Vehicle Color Figures 6-9
IGN	X11-Pin 6	RED	PINK
BRAKE +	X9-Pin 5	BLUE	PINK
BRAKE -	X9-Pin 3	WHITE/BROWN	ORANGE
GROUND	Figure 8	BLACK	BROWN
VSS	X2-Pin H1	VIOLET	GREEN/WHITE

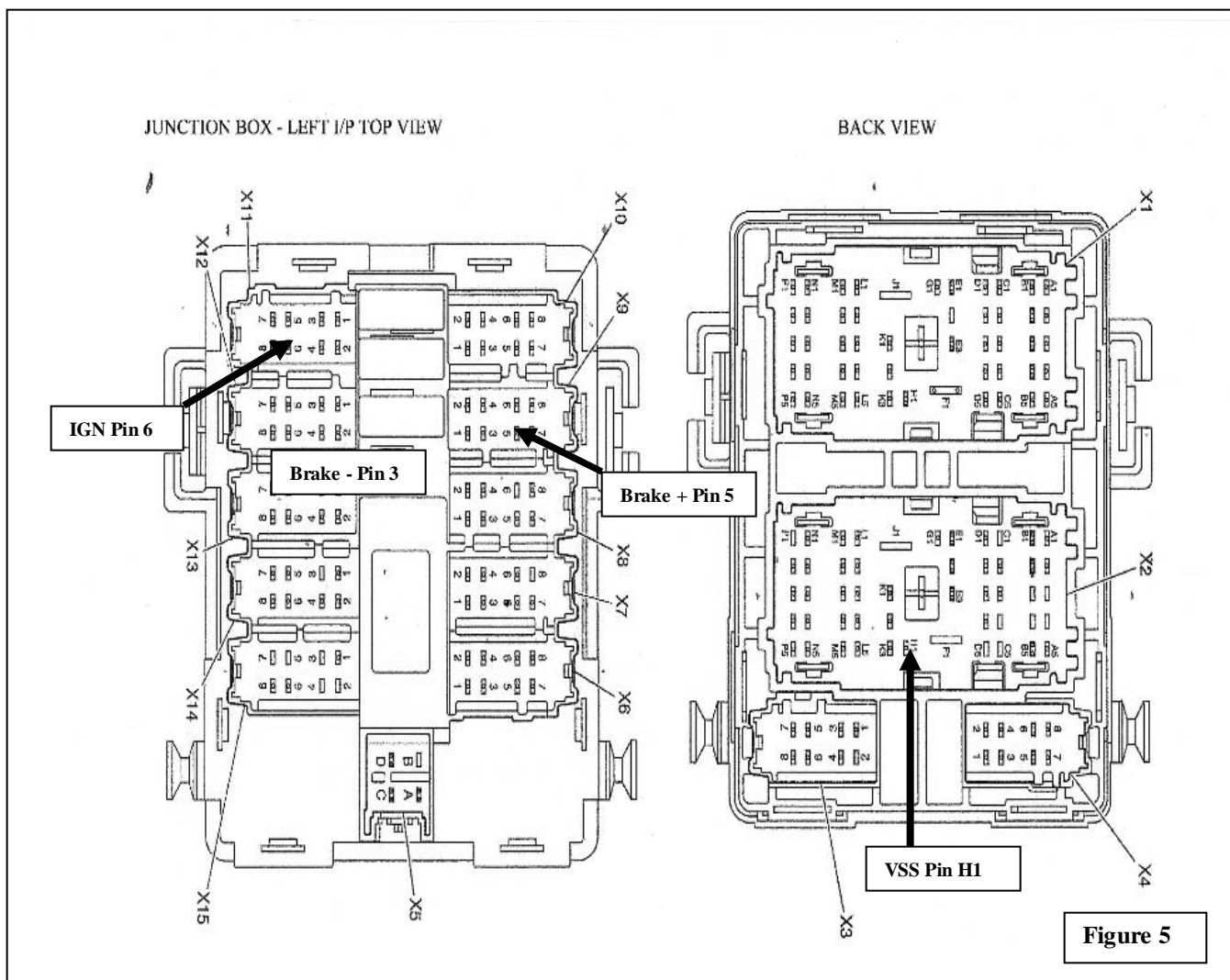
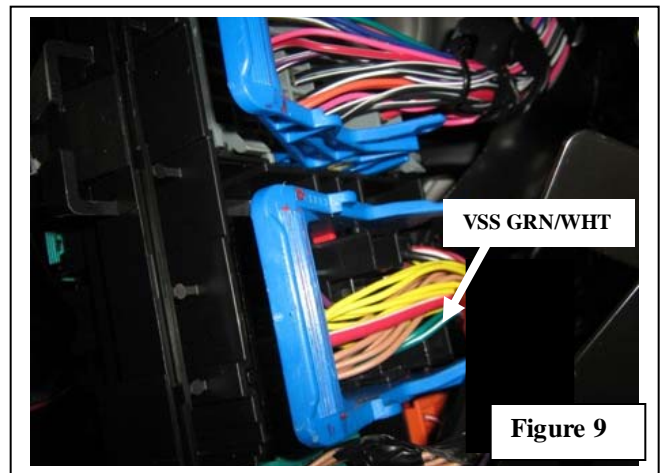
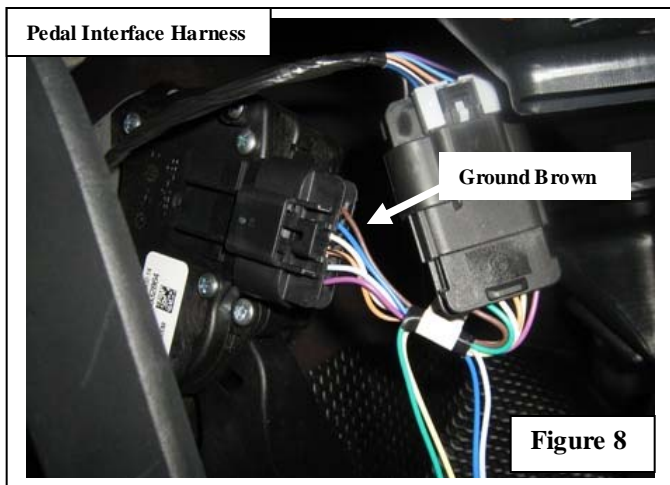
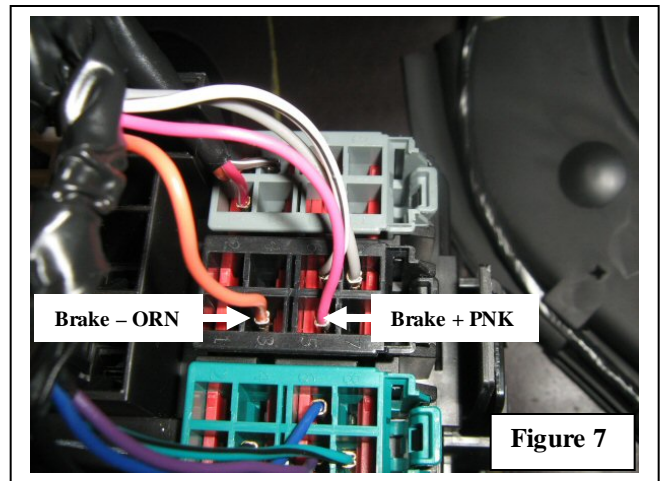
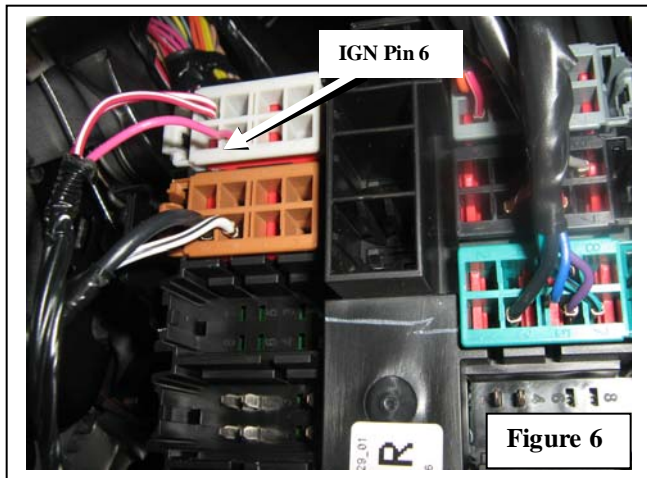

Figure 5



SOLDER ALL CONNECTIONS USING THE PICTURES BELOW



D. Wiring Connections (continued)



1. Use solder joint to make all connections.
Figures 6-9

E. Install Control Switch



1. Use the **level wedges** on the Control Switch at an angle template to drill a 3/8" or 9.5mm hole in the lower shroud of the steering column cover. Position lock-washers as shown. **Figures 10-11**
2. Apply nut and position Control Switch for driver's best view.
3. Assemble (2) 3-pin connectors from the sack parts to the mating wire colors on the Control switch harness. Use the diagram to mate the module harness to switch harness. **Figure 12**
4. Route the assembled Control Switch harness to the mating connector of the Cruise Control module.
5. Secure the Control Switch harness with zip ties away from moving parts.

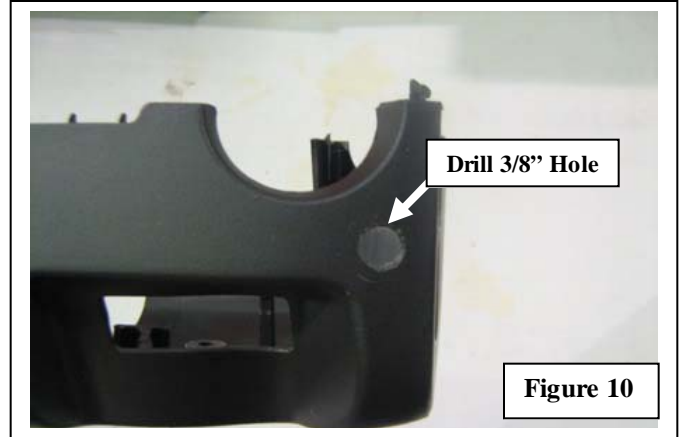

Figure 10

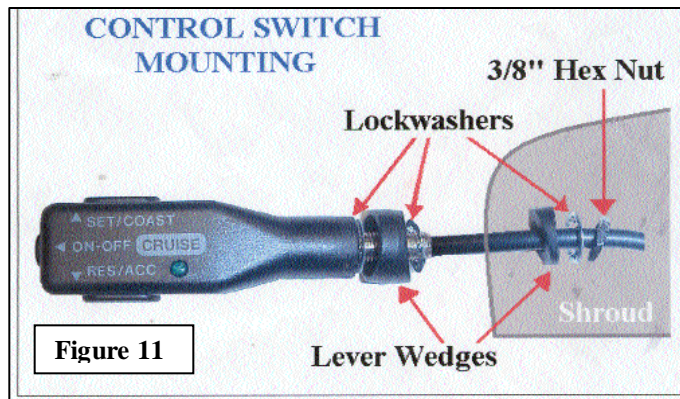

Figure 11

F. Testing



1. Reconnect negative battery cable and torque to 35 lbs. Reenter anti-theft radio codes.
2. Turn ignition on. Apply the on/off button of Cruise Control Switch.

G. Reassembly



1. Reinstall all removed pieces taking care to ensure harnesses and wiring connections are properly secured.
2. Make sure all harnesses are not pinched or bound by trim pieces.

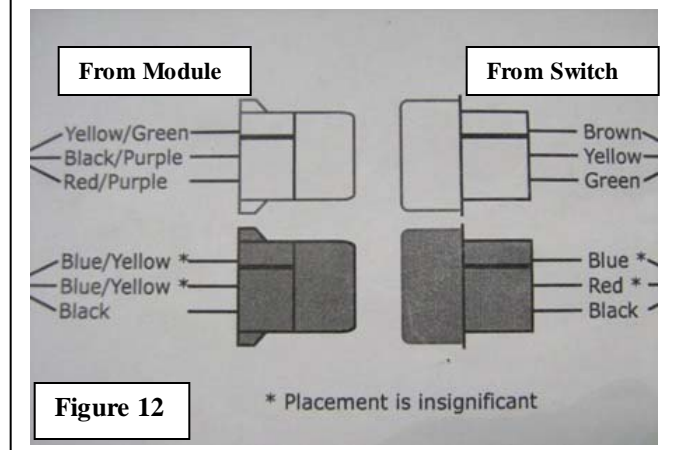
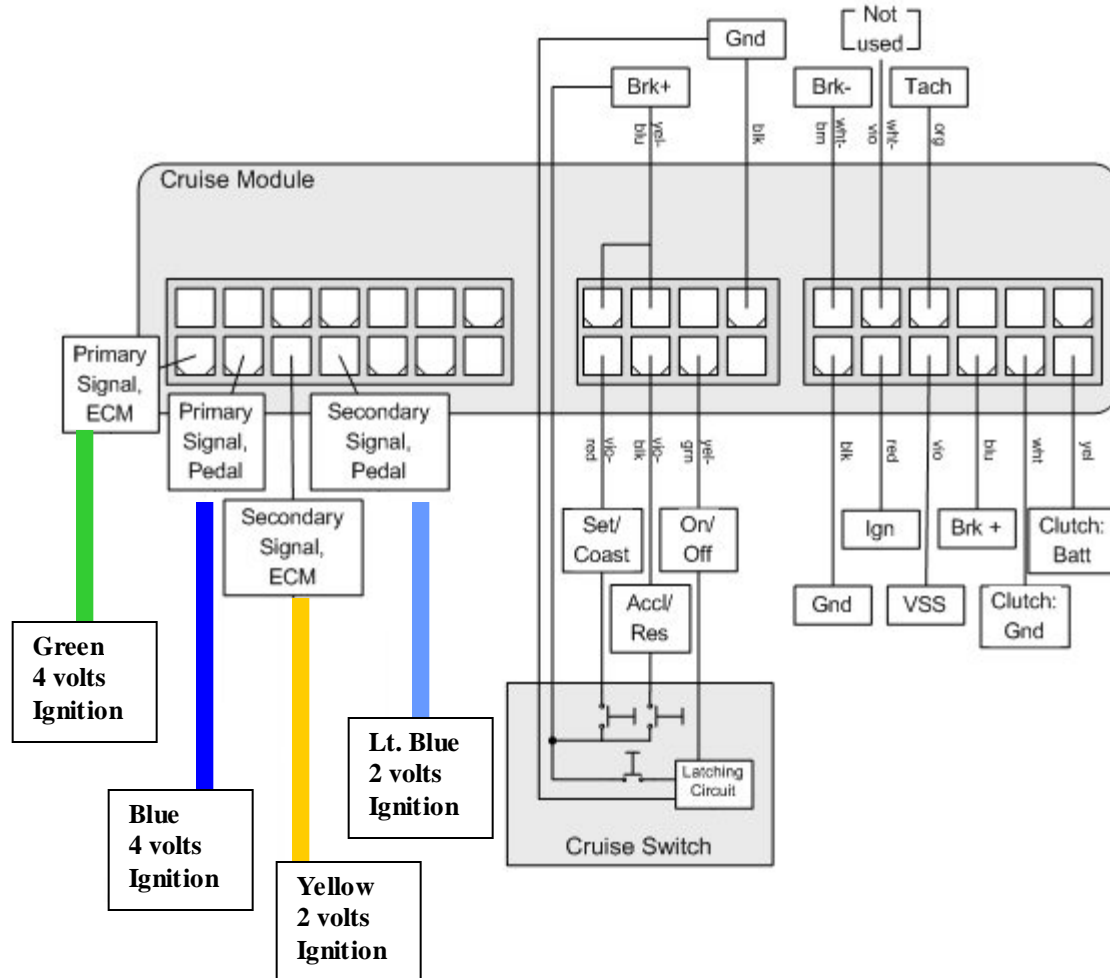

Figure 12





Figure 13

H. Wiring Diagram



Note: All Pedal Interface Harness Voltages are with pedal fully depressed

TROUBLESHOOTING

Function	Color	Results	Fault Conditions
Ignition	Red	+12V when switched on and +0V when switched off. Ignition must be greater than +10V while cranking vehicle.	No power, voltage drop, or intermittent connection will cause Loss of pedal or "Limp Mode" condition.
Brake positive +	Blue	"Hot" side of brake switch. +12V all the time.	Cruise will not function if this connection is not installed correctly.
Brake negative -	Brown/White	"Cold" side of Brake switch. Zero (0) resistance to ground when brake is not pressed. +12V when brake is pressed.	Cruise will not function if this connection is not installed correctly. If connection is good, and there is a high resistance to ground, a 5 terminal relay will be required to complete installation. See diagram below.
Ground	Black	Lowest resistance to ground closest to zero (0) ohms as possible. Use a vehicle ground point where other ground wires are connected to.	A bad ground connection will cause the following conditions: Cruise will not function; Loss of pedal or "Limp Mode" condition.
Clutch (GND triggered)	White	Ground active wire at switch when clutch is depressed.	Cruise will not function if wrong wire is connected –OR–  Cruise will not disengage when clutch is depressed.
Clutch (+12V triggered)	Yellow	+12V active wire at switch when clutch is depressed.	Cruise will not function if wrong wire is connected –OR–  Cruise will not disengage when clutch is depressed.

5 Terminal Relay for Brake Switch

