

## 250-9006

2010-2013 SUZUKI SX4

**AUTOMATIC AND MANUAL TRANSMISSION  
CRUISE CONTROL INSTALLATION INSTRUCTIONS**

### SERVICE PART NUMBERS

ITEM	QTY	DESCRIPTION	PART NUMBER
1	1	CONTROL MODULE	250-2736
2	1	MAIN HARNESS	250-2712
3	1	ECM HARNESS	250-2737
4	1	SWITCH	250-2721
5	1	SACK PARTS	250-2738
6	1	BRAKE HARNESS, RED	250-2739
7	1	CLUTCH SWITCH	250-4206



**1-800-343-1382**

**Please call for technical assistance.  
You will need your invoice number.**

# INSTALLATION

## A. INSTALLATION PREPARATION:

1. **DISCONNECT NEGATIVE BATTERY CABLE BEFORE INSTALLATION. FIGURE 1**
2. REMOVE THE **BOTTOM** CONNECTOR **EO1** OF THE ECM. **FIGURE 2**
3. LOCATE **RED/WHITE** WIRE IN **PIN 24** AND **LIGHT GREEN** WIRE IN **PIN 26** AT THE CONNECTOR. **FIGURE 3**

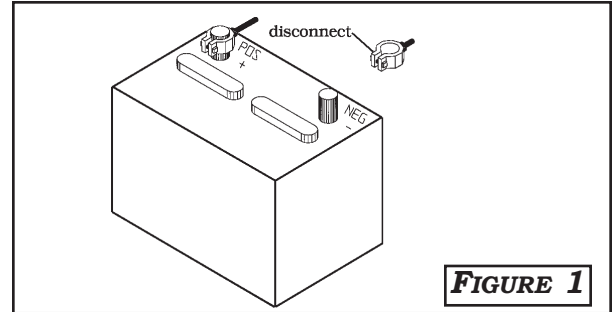

**FIGURE 1**

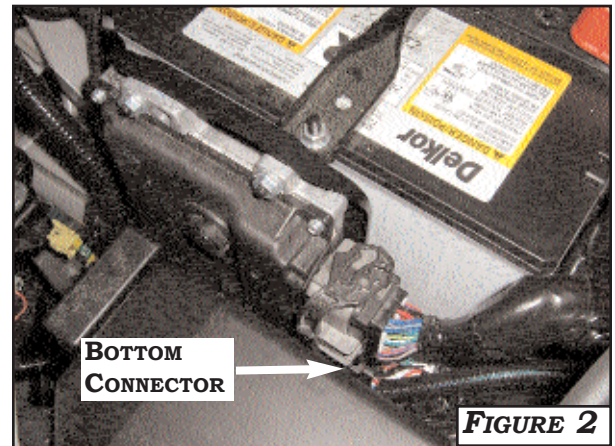

**FIGURE 2**

## B. HARNESS INSTALLATION:

1. LOCATE THE (3) WIRE ECM HARNESS IN KIT. LOCATE **LIGHT GREEN** WIRE IN **PIN 24** AND **RED/WHITE** WIRE IN **PIN 26**. CUT OFF TERMINAL FROM **GREEN** WIRE OF ECM HARNESS AND SOLDER TO **LIGHT GREEN** WIRE IN **PIN 24** OF EO1. CUT OFF TERMINAL FROM THE **WHITE** WIRE OF ECM HARNESS AND SOLDER TO **RED/WHITE** WIRE IN **PIN 26** OF EO1. **NOTE: YELLOW WIRE IN SUPPLIED ECM HARNESS IS NOT REQUIRED FOR PREWIRED APPLICATIONS. FIGURE 3.** CONTINUE TO PART C.

**NOTE: IF POSITIONS 24, 25 AND 26 DO NOT HAVE THE WIRING PRESENT, REMOVE THE PLASTIC INSERTS IN PINS 24, 25, AND 26.**

2. USE A PRECISION TOOL OR SMALL SCREWDRIVER TO RELEASE THE RETAINER OF THE CONNECTOR. THE RETAINER WILL ONLY PULL OUT AT 1/8". **FIGURE 4**
3. INSERT THE **GREEN** WIRE OF ECM HARNESS IN **PIN 24** OF EO1. INSERT THE **YELLOW** WIRE OF ECM HARNESS IN **PIN 25** OF EO1. INSERT THE **WHITE** WIRE OF ECM HARNESS IN **PIN 26** OF EO1. RE-ASSEMBLE CONNECTOR, INCLUDING RETAINER. BE SURE TO PLACE CONNECTOR BACK ON ECM SECURELY.

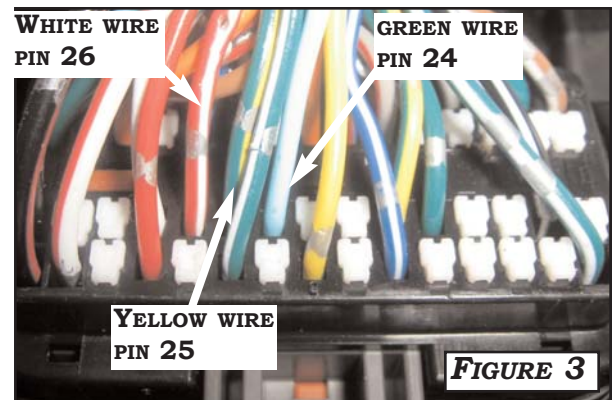

**FIGURE 3**

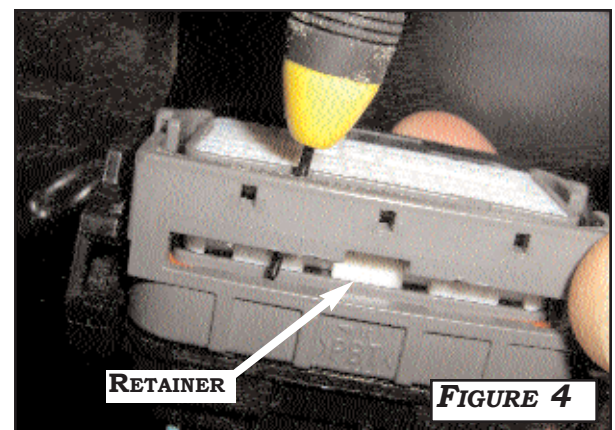

**FIGURE 4**

## C. HARNESS INSTALLATION (CONT):

5. REMOVE GLOVE BOX AND ROUTE HARNESS THROUGH ACCESS GROMMET ON PASSENGER SIDE FIREWALL AS SHOWN IN **FIGURE 5**. CONTINUE ROUTING HARNESS TO DRIVER SIDE.
6. REMOVE THE STEERING COLUMN SHROUD, LOWER DASH AND KICK PANELS. **FIGURE 6**
7. LOCATE BRAKE SWITCH. **IF WIRES ARE PRESENT IN PINS 1- 4, THIS STEP IS NOT REQUIRED.** REMOVE THE CONNECTOR AND RELEASE THE RETAINER. **FIGURE 7.** LOCATE THE **RED BRAKE HARNESS** IN KIT. INSERT THE TERMINAL FROM THE RED BRAKE HARNESS TO PIN 4 OF THE BRAKE SWITCH CONNECTOR. INSERT THE TERMINAL FROM THE **YELLOW WIRE** IN THE ECM HARNESS TO PIN 3 OF THE BRAKE SWITCH. **FIGURE 8.** RE-ASSEMBLE CONNECTOR, INCLUDING RETAINER.
8. **FOR MANUAL TRANSMISSION SX4 ONLY:** CUT WIRE IN **PIN 3** OF BRAKE SWITCH AND USE THE **250-4206 CLUTCH SWITCH** TO WIRE IN SERIES.
9. CONNECT THE **GREEN WIRE** FROM ECM HARNESS TO **GREEN WIRE** MARKED **CRUISE 2** OF THE MAIN CRUISE HARNESS.
10. CONNECT THE **WHITE WIRE** FROM ECM HARNESS TO **WHITE WIRE** MARKED **CRUISE 1** OF THE MAIN CRUISE HARNESS.
11. CONNECT THE TERMINAL END FROM THE RED BRAKE HARNESS (IF APPLICABLE) AND THE **RED WIRE** FROM THE MAIN CRUISE HARNESS TO THE **YELLOW/BLUE WIRE** (12V IGNITION) AT FUSE PANEL. FOR REFERENCE, THIS WIRE IS LOCATED ABOVE A BLACK/RED WIRE. **FIGURE 9**
12. CONNECT **BLACK WIRE** OF MAIN CRUISE HARNESS TO **BLACK/ORANGE GROUND WIRE** BEHIND THE DRIVER SIDE KICK PANEL AT THE VEHICLE GROUND POINT. **FIGURE 10.**

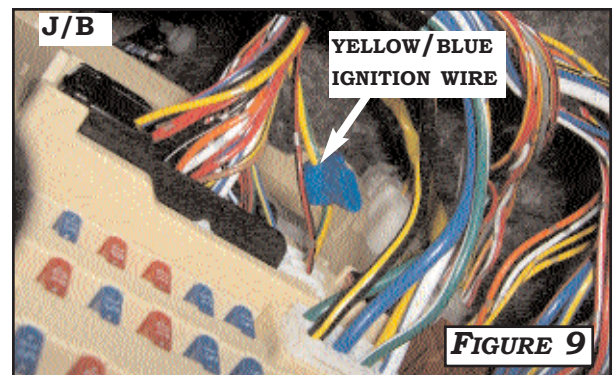
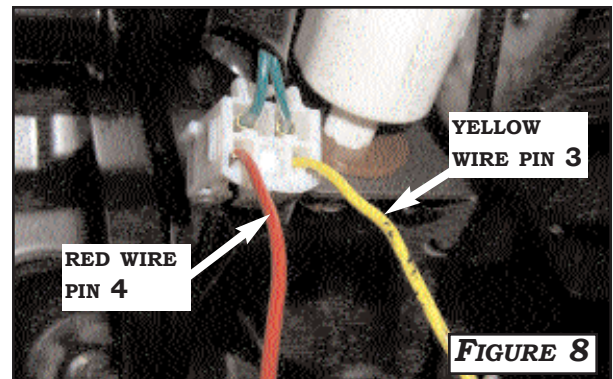
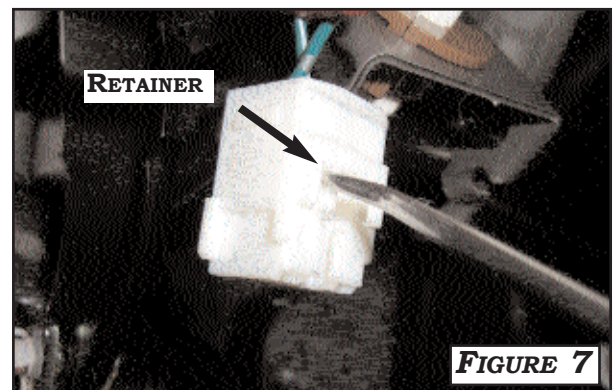
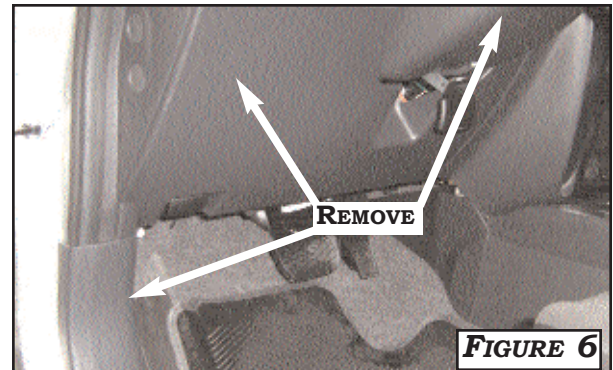
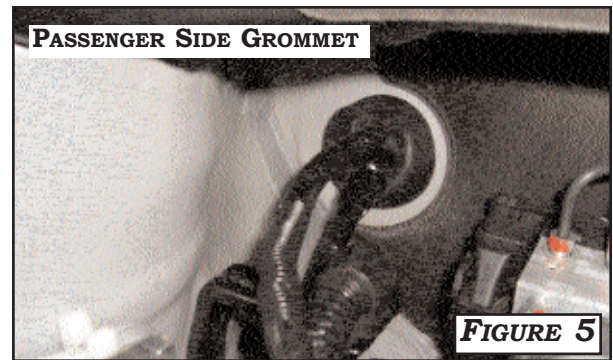

## D. SWITCH INSTALLATION:

1. MARK HOLE AS SHOWN IN **FIGURE 11**. USE THE **LEVER WEDGE** AS AN ANGLE TEMPLATE TO DRILL **9.5MM OR 3/8"** HOLE IN LOWER SHROUD. POSITION THE LOCK WASHERS AS SHOWN IN **FIGURE 12**. START NUT AND POSITION THE LETTERING FOR DRIVER'S BEST VIEW. FULLY SECURE NUT AT **2.5-2.8NM**. **DO NOT OVERTIGHTEN**.
2. LOCATE THE 4 PIN CONNECTOR CONNECTOR IN HARDWARE KIT. **FIGURE 13** INSTALL 4 PIN CONNECTOR ON **RED, BROWN, GREEN, AND YELLOW** SWITCH WIRES. **DO NOT USE THE BLACK AND BLUE SWITCH WIRES**. WRAP WIRES WITH ELECTRICAL TAPE.
3. CONNECT SWITCH HARNESS TO MAIN CRUISE HARNESS PER THE SYSTEM LAYOUT ON PAGE 5. CONNECT MAIN CRUISE HARNESS TO CRUISE CONTROL MODULE.

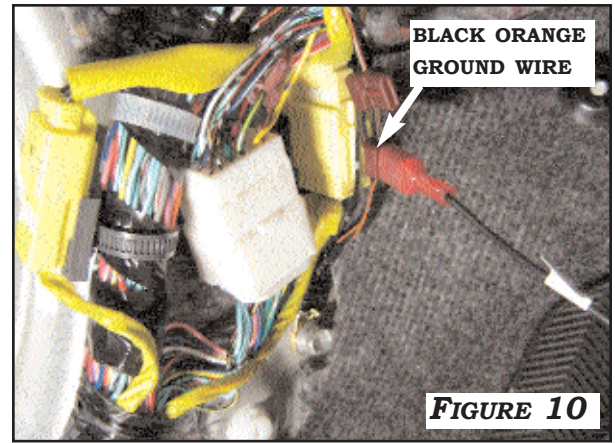

**FIGURE 10**

DRILL 9.5MM (3/8") HOLE AT 17° ANGLE  
TOWARDS STEERING WHEEL

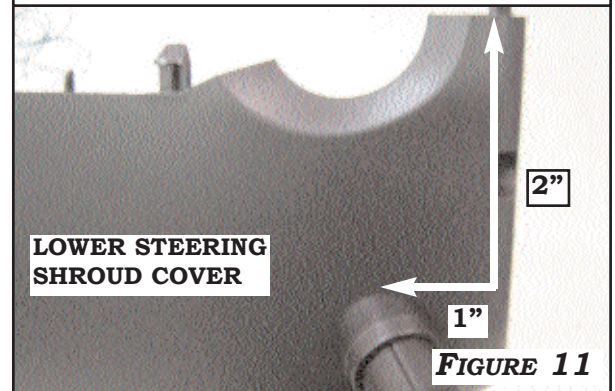

**FIGURE 11**

## E. REASSEMBLY:

1. REINSTALL ALL REMOVED PARTS FROM THE VEHICLE.
2. SECURE ALL WIRES WITH WIRE TIES.
3. RECONNECT NEGATIVE BATTERY CABLE.

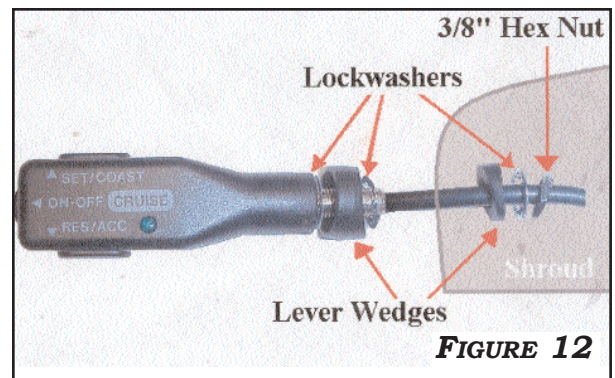
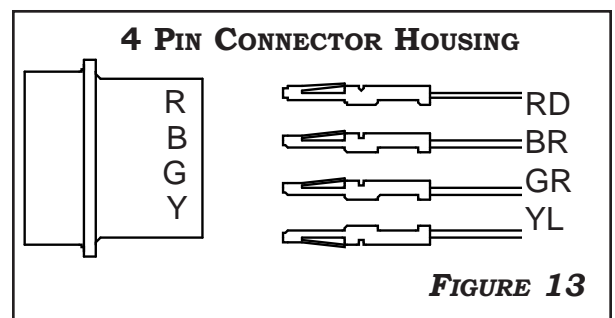

**FIGURE 12**

## F. TESTING:

1. TEST CRUISE FUNCTIONS IN ACCORDANCE WITH OPERATING INSTRUCTIONS. THE "CRUISE" INDICATOR LIGHT WILL ACTIVATE IN THE INSTRUMENT CLUSTER WHEN THE CONTROL SWITCH IS TURNED ON. THE CONTROL SWITCH INDICATOR LIGHT WILL NOT ILLUMINATE FOR THIS APPLICATION.

**IMPORTANT: VERIFY CRUISE DISENGAGES WHEN VEHICLE IS PUT IN NEUTRAL OR BRAKE IS DEPRESSED.**



**FIGURE 13**

**CAUTION: DO NOT USE THE BLACK AND BLUE WIRES FROM THE CONTROL SWITCH. WRAP WIRES WITH ELECTRICAL TAPE**

# PREWIRED SYSTEM LAYOUT

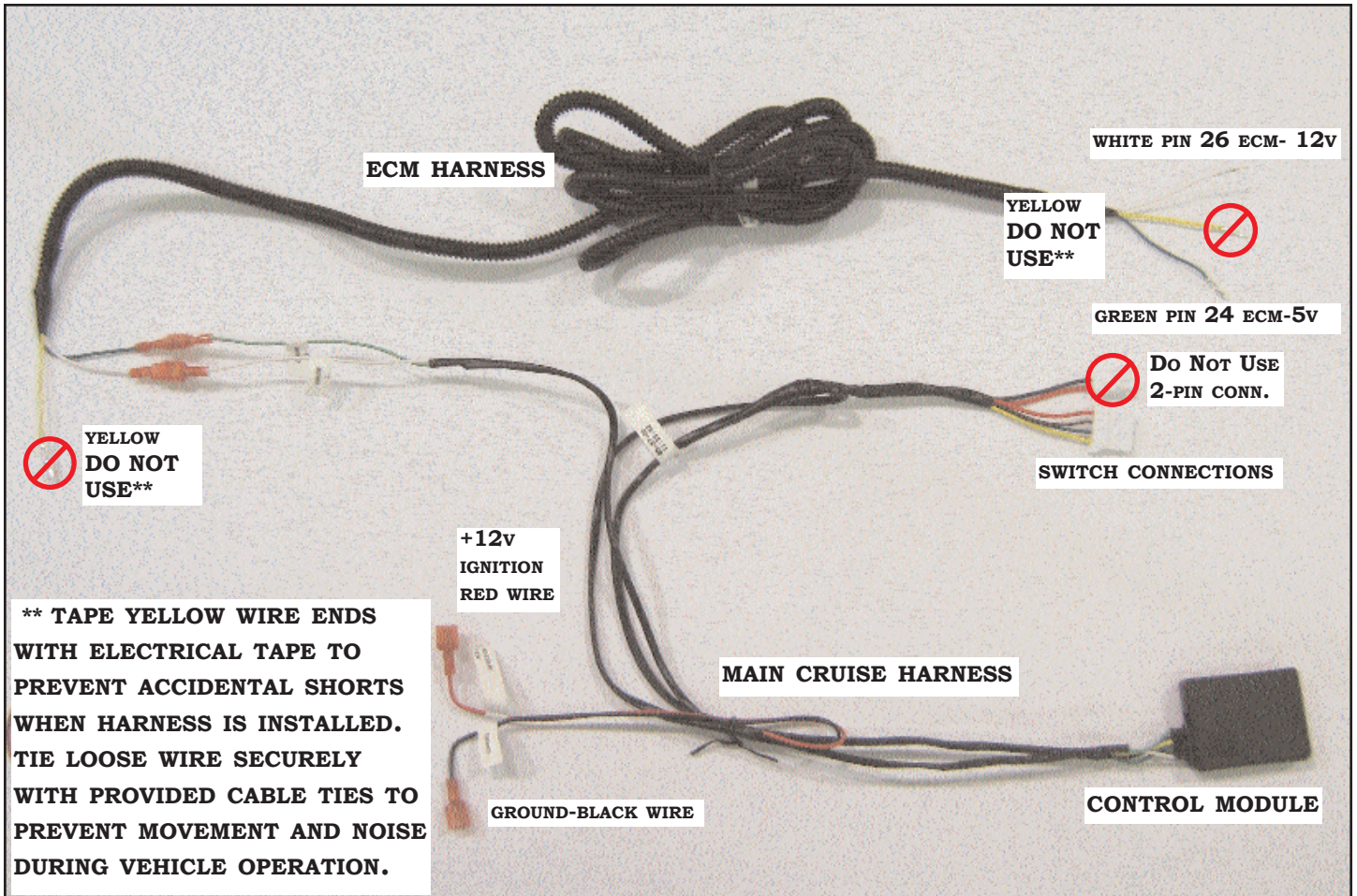

1. CHECK BLACK WIRE WITH METER FOR GROUND NO HIGHER THAN 3 OHMS OF RESISTANCE.
2. CHECK RED WIRE FOR IGNITION 12 VOLTS.
3. WITH EVERYTHING CONNECTED, CHECK WHITE WIRE AT THE CONTROL MODULE FOR 12 VOLTS WHEN PRESS AND HOLD "ON".

CHECK GREEN WIRE VOLTAGES AT THE CONTROL MODULE IN HARNESS:

- OFF: 5 VOLTS ON GREEN WIRE FROM THE ECM
- ON: 0 VOLTS ON GREEN WIRE
- ON WITH "SET" PRESSED: 2 VOLTS ON GREEN WIRE
- ON WITH "RESUME" PRESSED: 4 VOLTS ON GREEN WIRE

# NON PREWIRED SYSTEM LAYOUT

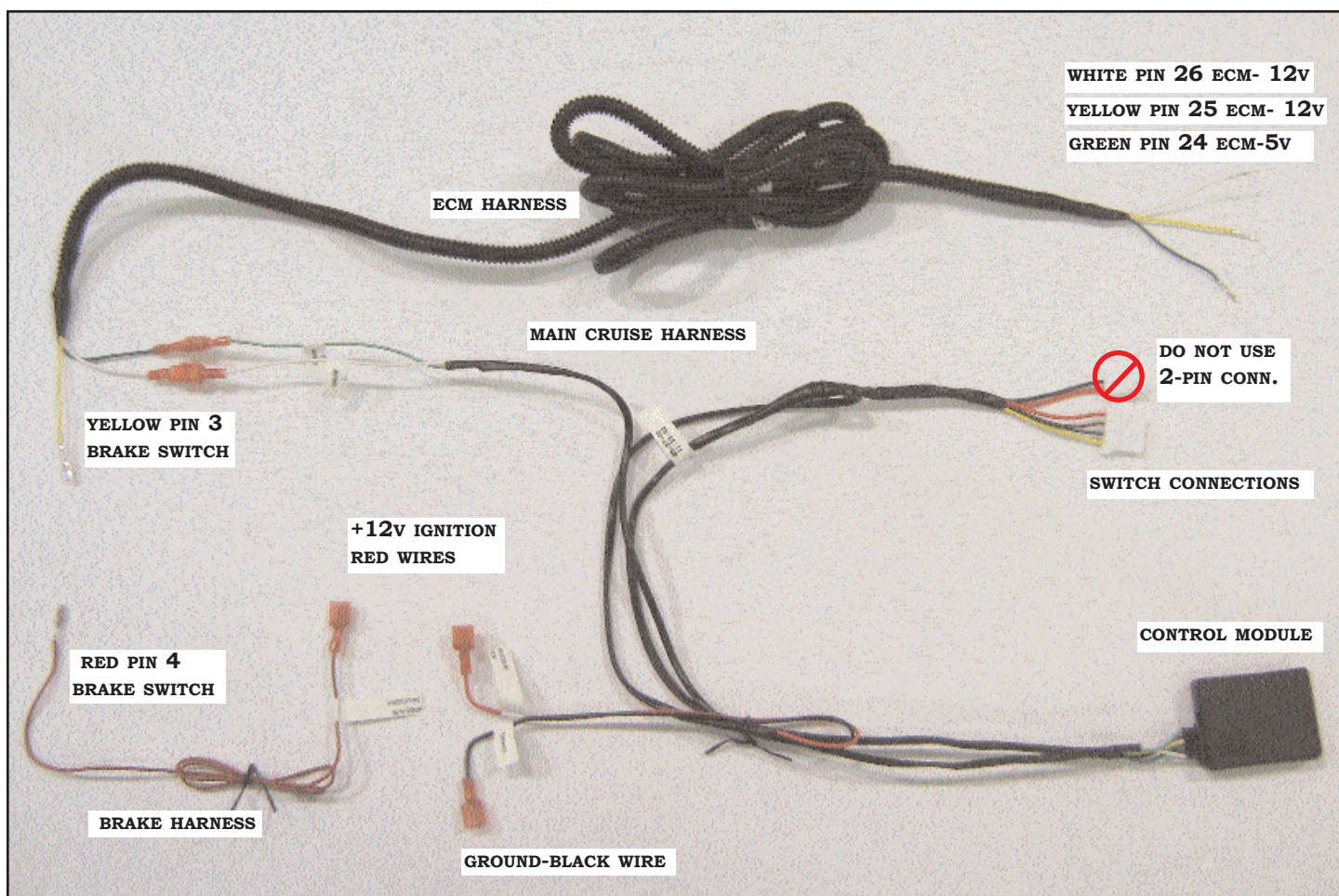

1. CHECK BLACK WIRE WITH METER FOR GROUND NO HIGHER THAN 3 OHMS OF RESISTANCE.
2. CHECK RED WIRE FOR IGNITION 12 VOLTS.
3. WITH EVERYTHING CONNECTED, CHECK WHITE WIRE AT THE CONTROL MODULE FOR 12 VOLTS WHEN PRESS AND HOLD "ON".

CHECK GREEN WIRE VOLTAGES AT THE CONTROL MODULE IN HARNESS:

- OFF: 5 VOLTS ON GREEN WIRE FROM THE ECM
- ON: 0 VOLTS ON GREEN WIRE
- ON WITH "SET" PRESSED: 2 VOLTS ON GREEN WIRE
- ON WITH "RESUME" PRESSED: 4 VOLTS ON GREEN WIRE