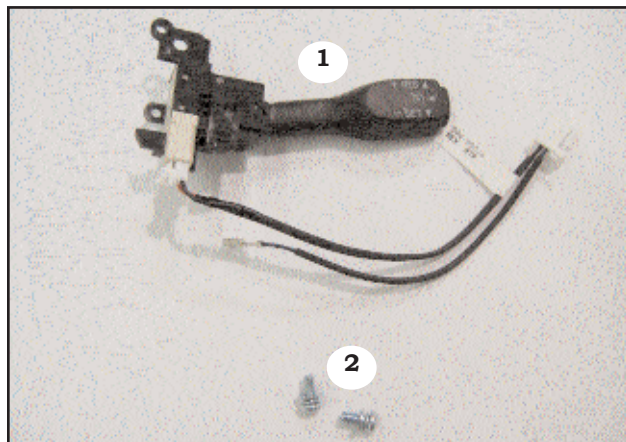


PONTIAC VIBE

PART NUMBER: 250-1731



BASE KIT CONTENTS

ITEM	QTY	DESCRIPTION
1	1	CONTROL SWITCH ASSEMBLY
1	2	SCREWS (M5)

HARDWARE BAG CONTENTS

ITEM	QTY	DESCRIPTION
1	1	CRUISE ECM HARNESSES FOR COROLLA
2	1	CRUISE ECM HARNESS FOR TACOMA

ADDITIONAL ITEMS REQUIRED FOR INSTALL

ITEM	QTY	DESCRIPTION
1	1	STOP SWITCH ASSEMBLY (PRIUS)
1	1	CLUTCH SWITCH (FOR MANUAL TRANS.)

CONFLICTS

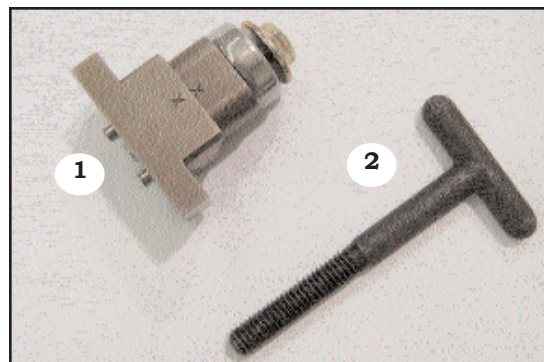
**NOTE: NOTE: ALL COROLLA VEHICLES WITH VIN'S BEGINNING WITH "2T1", AND AUTOMATIC TRANSMISSION VEHICLES WITH VIN'S BEGINNING WITH "1NX" REQUIRE PART ITEM 1 LISTED AT BAG CONTENTS. ALL TACOMA VEHICLES WITH V6 ENGINES USE ITEM 2.**

RECOMMENDED TOOLS

PERSONAL & VEHICLE PROTECTION	
SAFETY GLASSES	
FENDER COVER	
GLOVES (OPTIONAL)	
SPECIAL TOOLS	
BATTERY POST PROTECTOR	
INSTALLATION TOOLS	
TRIM REMOVAL TOOL	PHILLIPS SCREWDRIVER
10-MM WRENCH	T-30 BIT
3/4 WRENCH DRIVE	1/4" AND 1 1/2" HOLE SAW
SPECIAL CHEMICALS	

FORM #5156, REV. H, 09-06-11

TOOL SERVICE PARTS



SVC CONTENTS

ITEM	QTY	DESCRIPTION	PART NUMBER
1	1	CUTTING TOOL	250-2598
2	1	EXTRACTION TOOL	250-2600







GENERAL APPLICABILITY

COROLLA/MATRIX/PRIUS/TUNDRA/TACOMA/YARIS/VIBE MODELS

SERVICE PARTS

ITEM	PART#	DESCRIPTION
1	250-2707	STOP SWITCH ASSEMBLY (PRIUS)
2	250-2755	BRAKE HARNESS (09 PRIUS)
3	250-2663	CLUTCH SWITCH (TACOMA, YARIS)
4	250-2706	COROLLA ECM HARNESSES
5	250-2705	TACOMA ECM HARNESS
6	250-2709	TUNDRA HARNESS
7		

LEGEND

-  **STOP:** DAMAGE TO VEHICLE MAY OCCUR. DO NOT PROCEED UNTIL PROCESS COMPLIANCE HAS BEEN MET.
-  **OPERATOR SAFETY:** USE CAUTION TO AVOID RISK OF INJURY.
-  **CRITICAL PROCESS:** PROCEED WITH CAUTION TO ENSURE A QUALITY INSTALLATION. THESE POINTS WILL BE AUDITED ON A COMPLETED VEHICLE INSTALLATION.
-  **GENERAL PROCESS:** THIS HIGHLIGHTS SPECIFIC PROCESSES TO ENSURE A QUALITY INSTALLATION. THESE POINTS WILL BE AUDITED DURING THE ACCESSORY INSTALLATION.
-  **TOOLS & EQUIPMENT:** THIS CALLS OUT THE SPECIFIC TOOLS AND EQUIPMENT REQUIRED FOR THE PROCESS.
-  **REVISION MARK:** THIS MARK HIGHLIGHTS A CHANGE IN INSTALLATION WITH RESPECT TO PREVIOUS ISSUE.

SPECIAL NOTE: INSTALLATION SEQUENCES

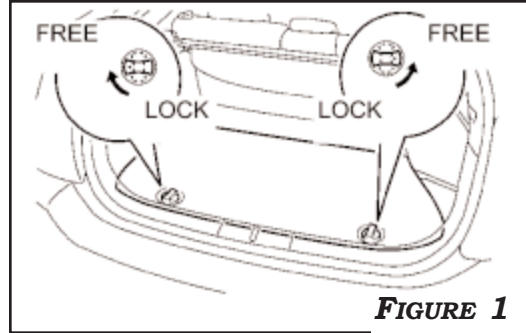
AFTER SAFETY MANDATED PREPARATORY STEPS HAVE BEEN TAKEN, THE INSTALLATION SEQUENCE IS THE SUGGESTED METHOD FOR COMPLETING THE ACCESSORY INSTALLATION. IN SOME INSTANCES THE SUGGESTED SEQUENCE IS WRITTEN FOR ONE ASSOCIATE TO INSTALL AND IN OTHERS THE SEQUENCE IS GIVEN AS PART OF A TEAM ACCESSORY INSTALLATION. UNLESS OTHERWISE STATED IN THE DOCUMENT, THE ASSOCIATES MAY PERFORM THE INSTALLATION STEPS IN ANY ORDER TO MAKE THE INSTALLATION AS EFFICIENT AS POSSIBLE WHILE MAINTAINING CONSISTENT QUALITY.

# PRIUS BATTERY

## BATTERY TERMINAL REMOVAL

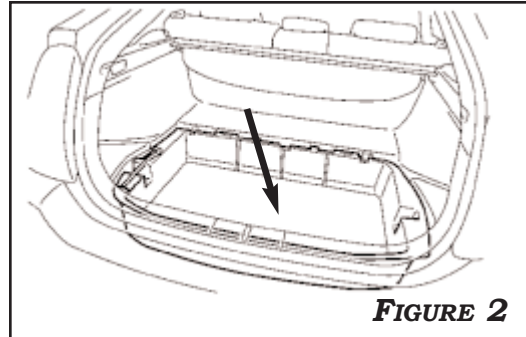


1. REMOVE THE REAR FLOOR BOARD SHOWN IN **FIGURE 1**.



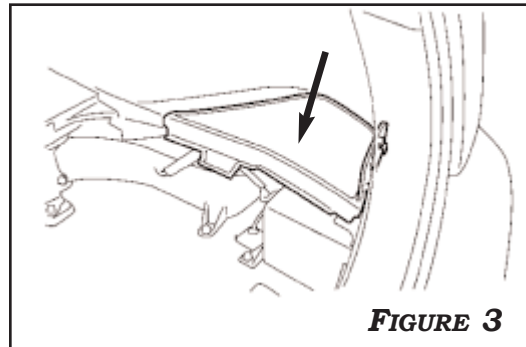
**FIGURE 1**

2. REMOVE THE DECK FLOOR BOX REAR SHOWN IN **FIGURE 2**.



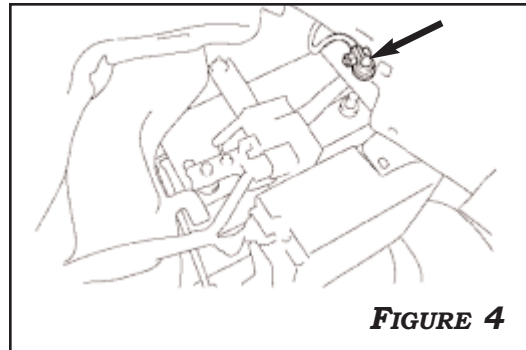
**FIGURE 2**

3. REMOVE THE REAR FLOOR BOARD SHOWN IN **FIGURE 3**.



**FIGURE 3**

4. DISCONNECT THE CABLE FROM THE NEGATIVE TERMINAL OF THE 12 V BATTERY AS SHOWN IN **FIGURE 4**.



**FIGURE 4**



**CAUTION: ENSURE THAT BATTERY HAS BEEN DISCONNECTED FOR MORE THAN 90 SECONDS PRIOR TO REMOVAL OF AIRBAG; FAILURE TO HEED THIS WARNING MAY RESULT IN AIRBAG DISCHARGE AND MAY CAUSE SERIOUS INJURY OR DEATH.**

# INSTALLATION

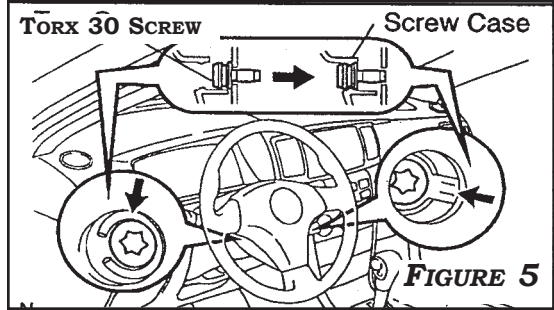
## CONTROL SWITCH

**LOCATION: RIGHT SIDE STEERING WHEEL COVER**

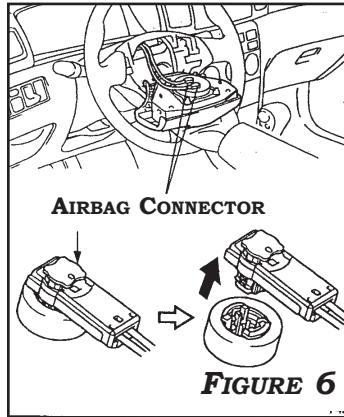


1. DISCONNECT NEGATIVE BATTERY CABLE FROM BATTERY

**CAUTION: ENSURE THAT BATTERY HAS BEEN DISCONNECTED FOR MORE THAN 90 SECONDS PRIOR TO REMOVAL OF AIRBAG; FAILURE TO HEED THIS WARNING MAY RESULT IN AIRBAG DISCHARGE AND MAY CAUSE SERIOUS INJURY OR DEATH.**



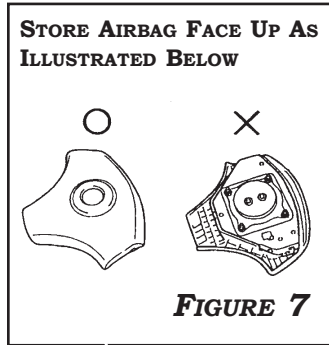
2. REMOVE AIRBAG BY RELEASING SIDE PANELS FROM STEERING WHEEL AND EXTRACTING THE TWO 30 TORX SCREWS AS ILLUSTRATED IN **FIGURE 5**.



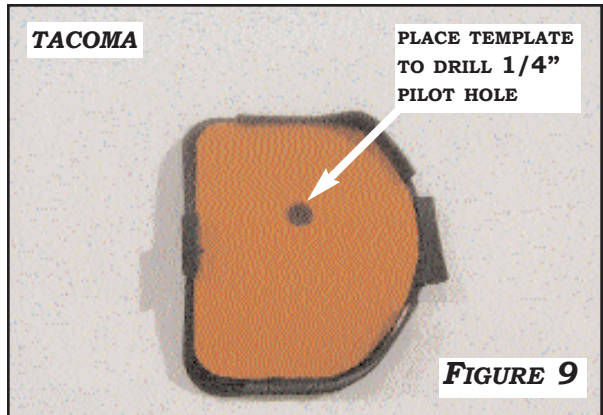
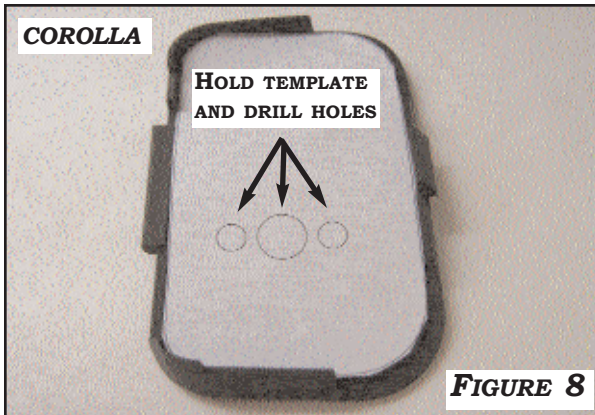
3. UTILIZE SMALL SCREWDRIVER TO REMOVE AIRBAG CONNECTORS AS ILLUSTRATED IN **FIGURE 6**.



**CAUTION: BE SURE TO STORE AIRBAG FACE UP AS ILLUSTRATED IN FIGURE 7 TO REDUCE INJURY IN EVENT OF ACCIDENTAL DISCHARGE OF AIRBAG.**



4. USING THE **SWITCH HOLE CUTTING TEMPLATES** ON PAGE 19, PLACE THE TEMPLATE ON THE INSIDE OF THE TRIM PIECE AS SHOWN AND DRILL TWO (2) 5MM (13/64") HOLES AND ONE (1) 8MM (11/32") HOLE. ANOTHER SET OF HOLES WILL NEED TO BE DRILLED FOR THE **PRIUS**. DRILL A 1/4" PILOT WHEN USING THE **TACOMA** TEMPLATE BEFORE DRILLING THE 1 1/2" HOLE. **FIGURES 8-11**.

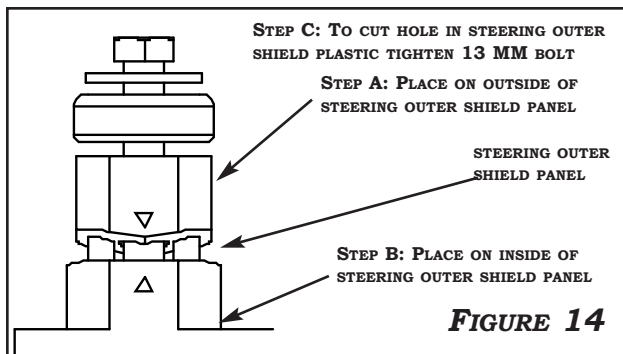
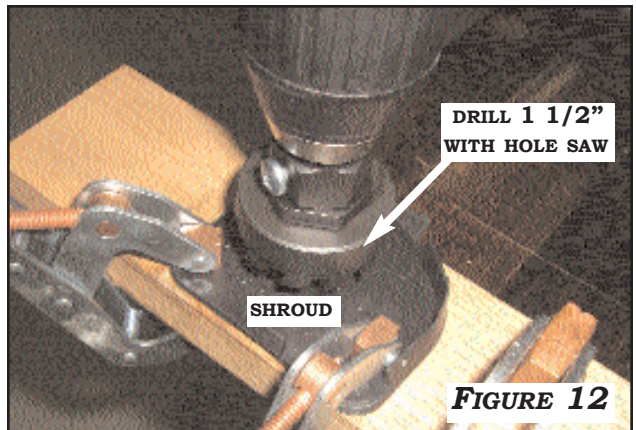
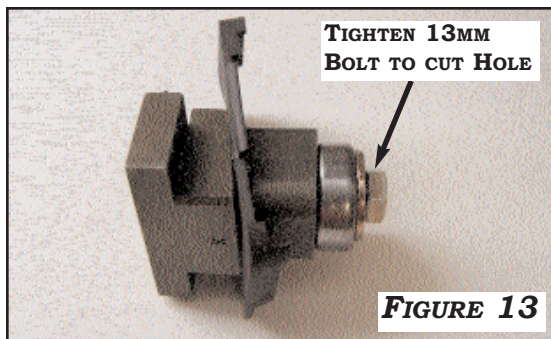
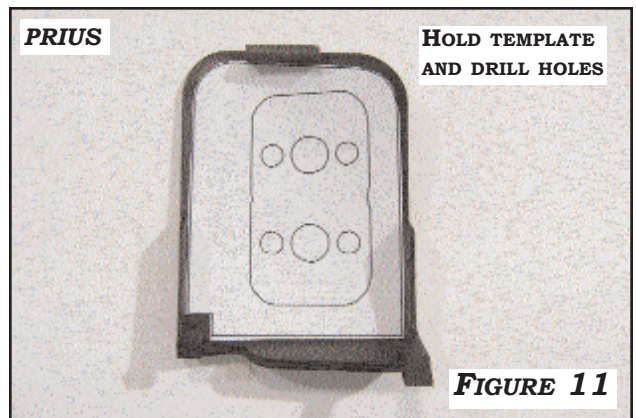
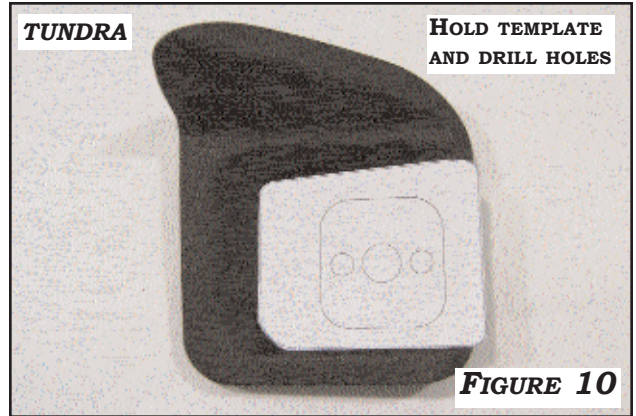


# INSTALLATION

## CONTROL SWITCH CONTINUED



5. IF USING THE TACOMA TEMPLATE, DRILL A 1 1/2" HOLE INTO THE SHROUD FOR THE CONTROL SWITCH. **FIGURE 12**
6. USING THE **SWITCH HOLE CUTTING TOOL, 250-2598**, INSERT THE CUTTING TOOL INTO THE DRILL HOLES OF TRIM PIECE AND WITH 13MM SOCKET, TIGHTEN THE SCREW UNTIL PLASTIC HOLE IS CUT OUT. **FIGURES 13 & 14.**
7. SOMETIMES THE CUTTING DIE MAY GET LODGED IN THE STEERING SHROUD MATERIAL; IN THIS CASE, UTILIZE THE CUTTING EXTRACTION TOOL, **250-2600**, TO REMOVE DIE. THREAD T-BOLT INTO DIE AS SHOWN IN **FIGURE 15** AND PULL TO REMOVE DIE FROM STEERING SHROUD.



# INSTALLATION

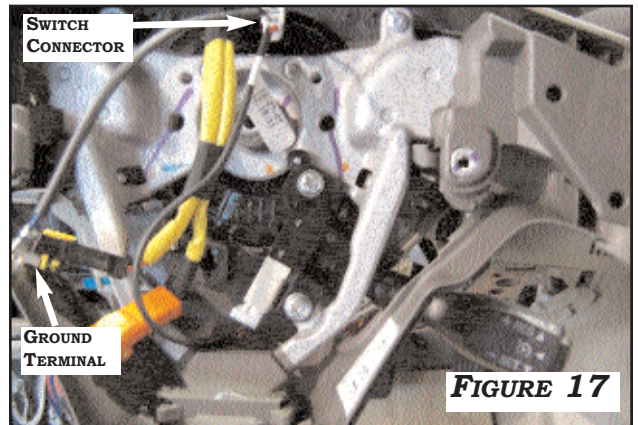
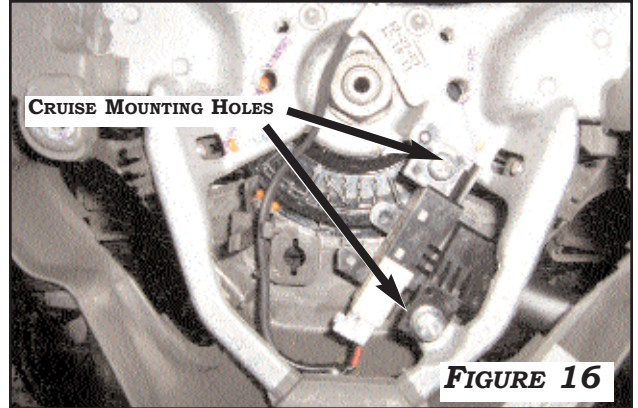
## CONTROL SWITCH CONTINUED



7. MOUNT CRUISE CONTROL SWITCH WITH TWO (2) PHILLIPS SCREWS PROVIDED. REMOVE GROUND TERMINAL AND DUMMY HORN/CRUISE CONNECTOR FROM STEERING WHEEL AND DISCARD. PLUG IN CRUISE SWITCH CONNECTOR AND RECONNECT GROUND TERMINAL. **NOTE: PRIUS APPLICATIONS, TAPE OFF OR REMOVE UNUSED GROUND TERMINAL ON CRUISE SWITCH CONNECTOR. FIGURES 16-18**



8. REINSTALL AIRBAG.



## TESTING



1. RECONNECT NEGATIVE BATTERY CABLE AND TORQUE TO 3FT\*LBS.



2. TURN THE IGNITION TO THE "ON" POSITION. PRESS THE "CRUISE ON-OFF" BUTTON. THIS TURNS THE SYSTEM ON. THE INDICATOR LIGHT IN THE INSTRUMENT PANEL WILL COME ON. IF THE LIGHT DOES NOT COME ON, OR FLASHES, DISCONNECT NEGATIVE BATTERY TERMINAL AND CONTINUE TO NEXT PAGE.



3. IF THE INDICATOR LIGHT IN THE INSTRUMENT PANEL COMES ON, CHECK CRUISE FUNCTIONALITY. ENSURE CRUISE DISENGAGES WHEN VEHICLE IS SHIFTED INTO NEUTRAL OR CLUTCH IS DEPRESSED. ALSO ENSURE CRUISE DISENGAGES WHEN BRAKE IS DEPRESSED.



# COROLLA/VIBE INSTALLATION

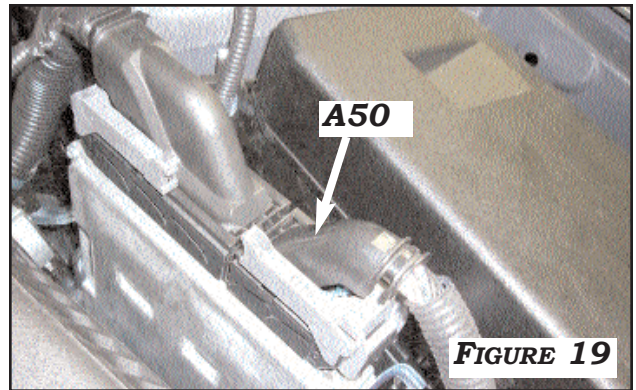


**CAUTION:** ENSURE THAT BATTERY HAS BEEN DISCONNECTED FOR MORE THAN 90 SECONDS PRIOR TO REMOVAL OF AIRBAG; FAILURE TO HEED THIS WARNING MAY RESULT IN AIRBAG DISCHARGE AND MAY CAUSE SERIOUS INJURY OR DEATH.

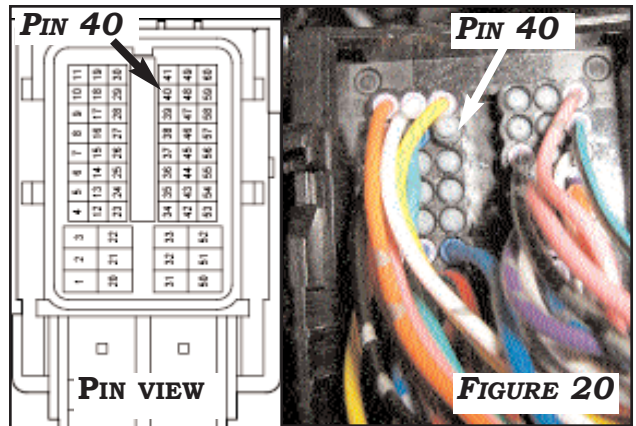
## CRUISE ECM HARNESS-COROLLA



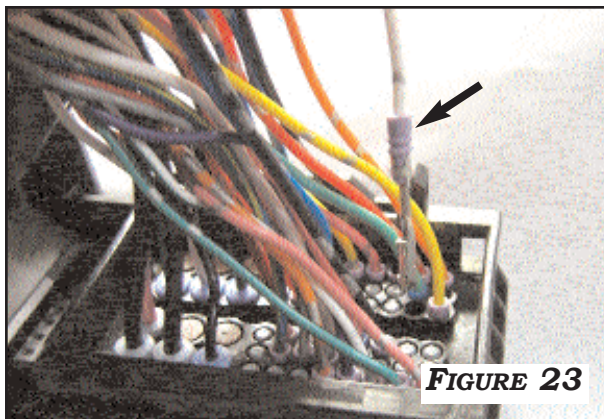
1. DISCONNECT NEGATIVE BATTERY CABLE FROM BATTERY.
2. LOCATE CONNECTOR **A50** AT DRIVER SIDE IN THE ENGINE COMPARTMENT. RELEASE CONNECTOR FROM THE ECM AND REMOVE THE PLASTIC COVER. **FIGURE 19**.
3. LOCATE PIN **40**, IN WHICH, IF PRE-WIRED, WOULD BE A **BLUE/BLACK WIRE**. IF WIRE IS PRESENT, CHECK CRUISE SWITCH CONNECTIONS. IF WIRE IS NOT PRESENT, REMOVE THE RUBBER SEAL IN PIN **40**. **FIGURE 20**. **BE SURE TO PULL OUT TERMINAL RELEASE TRACK AT THE CENTER OF CONNECTOR. FIGURE 21**. USE ECM TERMINAL WITH RUBBER SEAL AS SHOWN IN **FIGURE 22**. INSERT THE ECM TERMINAL FROM THE **WHITE (MAY BE BLACK)** CRUISE ECM HARNESS TO PIN **40** OF CONNECTOR **A50** CAREFULLY LOCKING TERMINAL INTO PLACE. **FIGURE 23**. PRESS IN RUBBER SEAL ON HARNESS INTO CONNECTOR HOUSING.
4. REASSEMBLE CONNECTOR **A50** AND PLACE BACK ONTO ECM. ROUTE THE CRUISE ECM HARNESS THROUGH THE GROMMET ON THE FIREWALL AS SHOWN IN **FIGURE 24**.



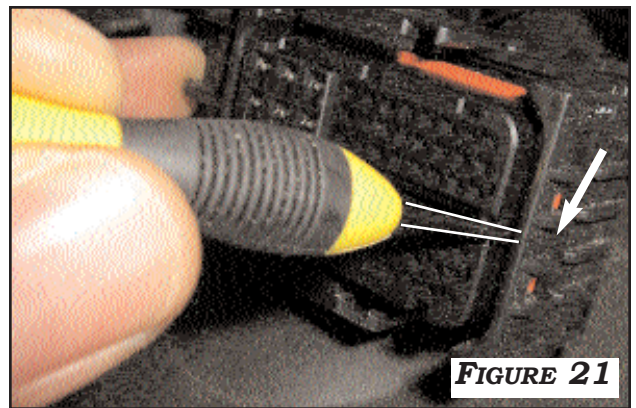
**FIGURE 19**



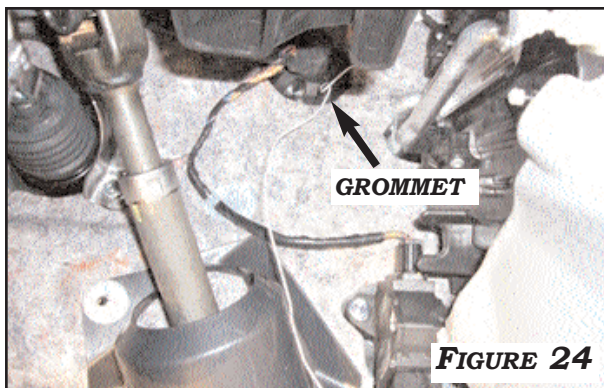
**FIGURE 20**



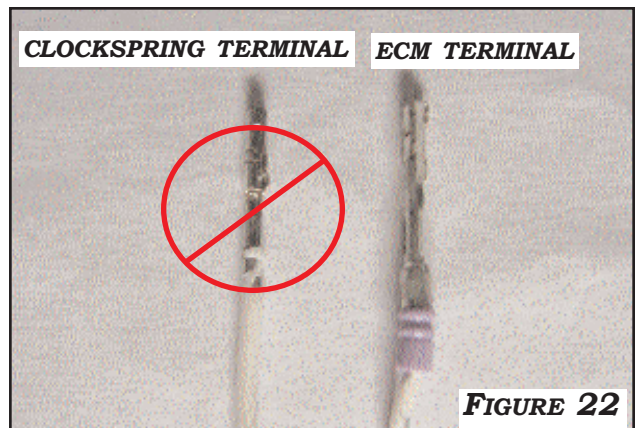
**FIGURE 23**



**FIGURE 21**



**FIGURE 24**



**FIGURE 22**

# COROLLA, VIBE, TACOMA, TUNDRA INSTALL

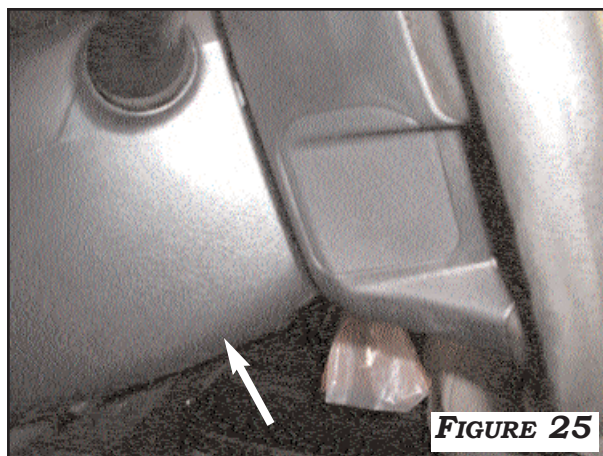
## CRUISE ECM HARNESS



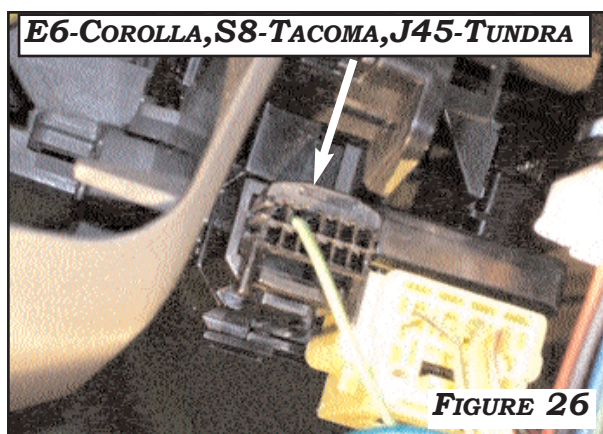
1. REMOVE LOWER STEERING WHEEL SHROUD. **FIGURE 25.**

2. LOCATE CONNECTOR **E6** (COROLLA) **S8** (TACOMA) OR **J45** (TUNDRA) BEHIND STEERING WHEEL AT RIGHT SIDE OF SUB ASSEMBLY. **FIGURE 26.** REMOVE CONNECTOR. **BE SURE TO PULL OUT TERMINAL RETAINER AT THE CENTER OF CONNECTOR. FIGURE 27.** IF PRESENT, REMOVE THE **YELLOW WIRE** IN **PIN 1** OF CONNECTOR **E6**. **SEE FIGURE 28.**

INSERT THE **CLOCK-SPRING** TERMINAL FROM THE COROLLA CRUISE ECM HARNESS (**WHITE** OR **BLACK** WIRE) TO **PIN 1** OF CONNECTOR **E6** OR **J45** FOR THE COROLLA AND TUNDRA. FOR TACOMA APPLICATIONS, INSERT THE TACOMA CRUISE ECM HARNESS TO **PIN 1** OF CONNECTOR **S8**. CAREFULLY LOCK TERMINAL INTO PLACE. **FIGURE 29.** PULL THE TERMINAL BACK GENTLY TO CHECK WHETHER IT IS LOCKED CORRECTLY.

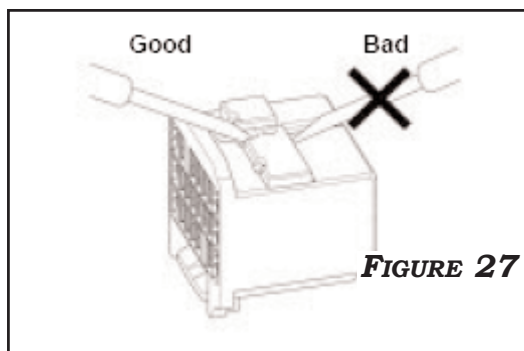


**FIGURE 25**

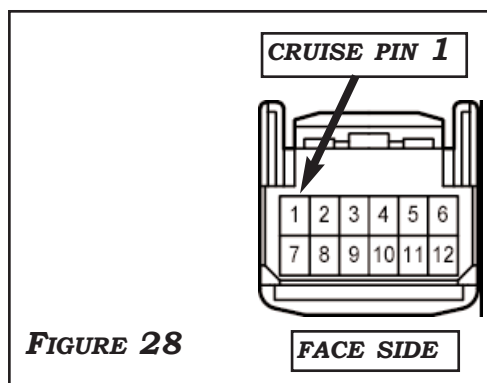


**E6-COROLLA, S8-TACOMA, J45-TUNDRA**

**FIGURE 26**

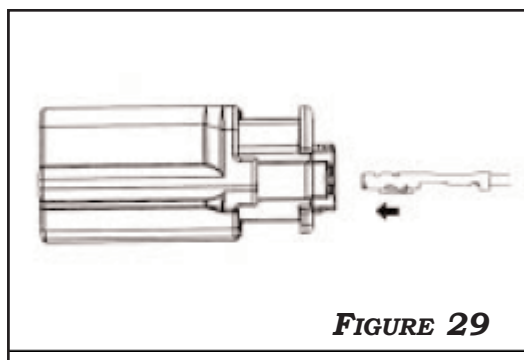


**FIGURE 27**



**FIGURE 28**

**FACE SIDE**



**FIGURE 29**

# COROLLA, VIBE, TACOMA, TUNDRA INSTALL

## CRUISE ECM HARNESS CONTINUED



3. IF **BROWN** OR **BROWN/WHITE** WIRE IS PRESENT IN **PIN 2** OF CONNECTOR **E6, S8, OR J45**, REASSEMBLE CONNECTOR AND SEE TESTING INSTRUCTIONS. **BE SURE RETAINER IS PRESSED IN BEFORE REINSTALLING CONNECTOR.**
4. IF **BROWN** OR **BROWN/WHITE** WIRE IS NOT PRESENT, INSERT THE **CLOCKSPRING** TERMINAL FROM THE COROLLA CRUISE ECM HARNESS (BLACK WIRE) TO **PIN 2** OF CONNECTOR **E6, S8, OR J45**. CAREFULLY LOCK TERMINAL INTO PLACE. **FIGURE 30**. REASSEMBLE CONNECTOR. **BE SURE RETAINER IS PRESSED IN BEFORE REINSTALLING.**
5. REMOVE THE DRIVER SIDE KICK PANEL. **FIGURE 31**. ROUTE THE GROUND HARNESS TO VEHICLE GROUND POINT. REMOVE THE 10MM GROUND SCREW. INSTALL THE **GROUND** TERMINAL FROM THE **BLACK** CRUISE ECM HARNESS TO GROUND POINT. **FIGURE 32**
6. FOR COROLLA, SEE TESTING INSTRUCTIONS. FOR OTHERS, CONTINUE TO NEXT PAGE.

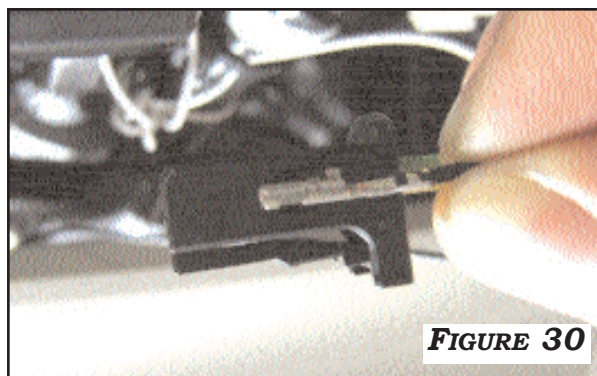


FIGURE 30

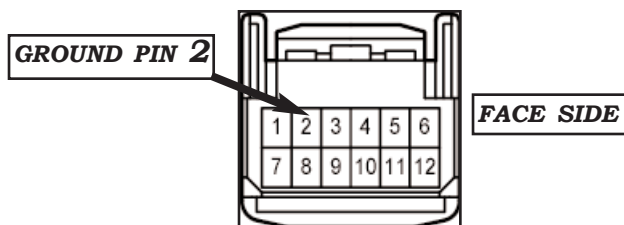


FIGURE 31

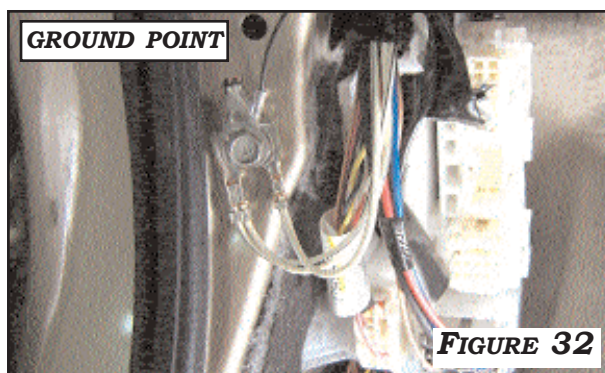


FIGURE 32



# TACOMA INSTALLATION

## TACOMA CRUISE ECM HARNESS



1. ROUTE THE TACOMA CRUISE ECM HARNESS TO THE ECM BEHIND THE GLOVE BOX. REMOVE GLOVE BOX. LOCATE WHITE CONNECTOR **E7** (SECOND FROM BOTTOM) OF THE ECM. **FIGURE 33**. **BE SURE TO PULL OUT TERMINAL RETAINER AT THE CENTER OF CONNECTOR. FIGURE 34.** INSERT **ECM** TERMINAL FROM THE TACOMA CRUISE ECM HARNESS TO THE FOLLOWING MODEL YEAR LOCATIONS: **FIGURE 35**

### 07-08 TACOMA

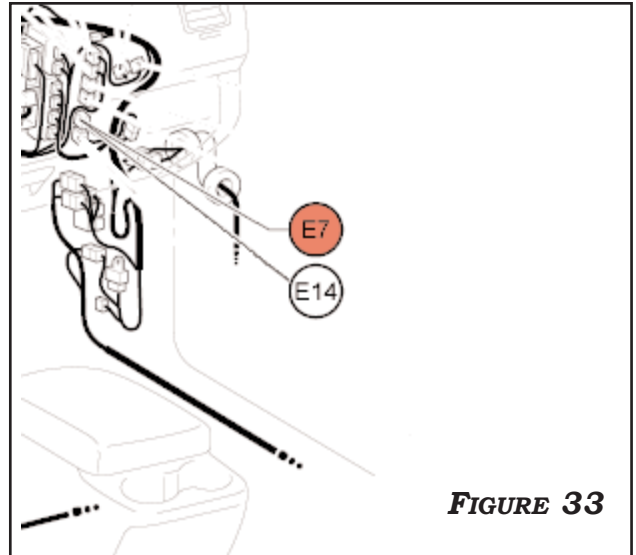
- 1GRFE ENGINE: CONNECTOR E7 PIN 2 BROWN/WHITE**  
**2TRFE ENGINE: CONNECTOR E7 PIN 31 BROWN/WHITE**

2. CAREFULLY LOCK THE TERMINAL INTO PLACE. PULL THE TERMINAL BACK GENTLY TO CHECK WHETHER IT IS LOCKED CORRECTLY. REASSEMBLE CONNECTOR AND PLACE BACK ONTO ECM. **BE SURE RETAINER IS PRESSED IN BEFORE REINSTALLING.** SECURE HARNESS WITH WIRE TIES.
3. REASSEMBLE ACCORDING TO BELOW INSTRUCTIONS, THEN REPEAT TESTING PROCEDURE.

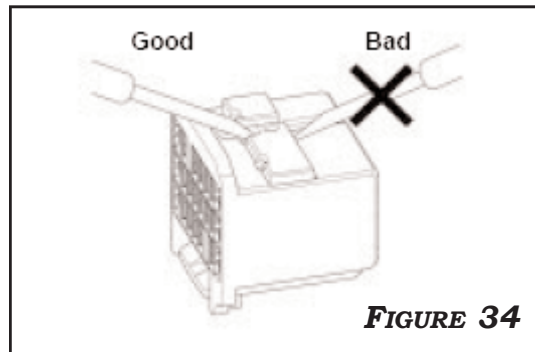
## REASSEMBLY



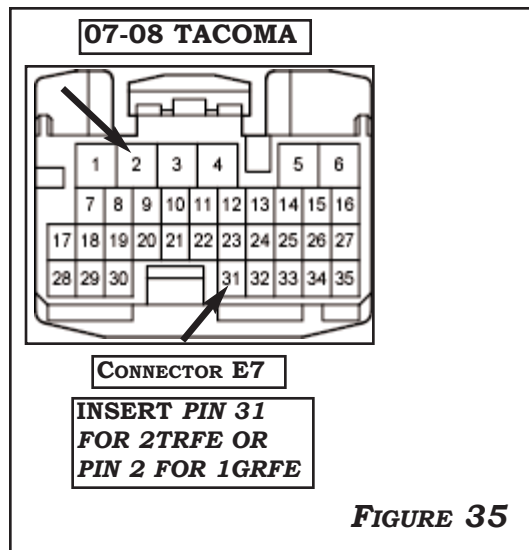
1. REINSTALL TRIM PIECES TAKING SPECIAL CARE TO ENSURE HARNESSSES AND WIRING CONNECTIONS ARE PROPERLY SECURED.
2. BE SURE HARNESS IS NOT PINCHED OR BOUND.



**FIGURE 33**



**FIGURE 34**



**FIGURE 35**

# TUNDRA INSTALLATION



**CAUTION: ENSURE THAT BATTERY HAS BEEN DISCONNECTED FOR MORE THAN 90 SECONDS PRIOR TO REMOVAL OF AIRBAG; FAILURE TO HEED THIS WARNING MAY RESULT IN AIRBAG DISCHARGE AND MAY CAUSE SERIOUS INJURY OR DEATH.**

## TUNDRA CRUISE ECM HARNESS



**NOTE: TUNDRA APPLICATIONS MAY REQUIRE ADDING LENGTH TO THE COROLLA ECM HARNESS (WHITE OR BLACK WIRE) TO REACH THE ECM, OR A LONGER HARNESS (250-2709) CAN BE ORDERED.**

1. ROUTE THE COROLLA CRUISE ECM HARNESS THROUGH THE GROMMET ON THE FIREWALL. LOCATE CONNECTOR **A24** AT PASSENGER SIDE IN THE ENGINE COMPARTMENT. RELEASE CONNECTOR FROM THE ECM AND REMOVE THE PLASTIC COVER. **FIGURE 36.**
2. LOCATE PIN **45**, IN WHICH IF PRE-WIRED WOULD BE A **BROWN WIRE.** **FIGURE 37.** IF BROWN WIRE IS PRESENT, REMOVE ECM TERMINAL FROM COROLLA CRUISE ECM HARNESS AND ATTACH TO FACTORY BROWN WIRE OF PIN 45, THEN REPEAT TESTING PROCEDURE. IF WIRE IS NOT PRESENT, REMOVE THE RUBBER SEAL IN PIN **45.** **BE SURE TO PULL OUT TERMINAL RETAINER AT THE CENTER OF CONNECTOR WITH SPECIAL TOOL.** **FIGURE 38.** USE ECM TERMINAL WITH RUBBER SEAL AS SHOWN IN **FIGURE 39.**
3. INSERT THE **ECM** TERMINAL FROM THE COROLLA CRUISE ECM HARNESS TO PIN **45** OF CONNECTOR **A24** CAREFULLY LOCKING TERMINAL INTO PLACE. PULL THE TERMINAL BACK GENTLY TO CHECK WHETHER IT IS LOCKED CORRECTLY. **NOTE: IF THE TERMINAL TO LOCKING CLIP DOES NOT LOCK FIRMLY, TERMINAL RETAINER CAN NOT LOCK AT FULL LOCK POSITION SO THE TERMINAL BACKS OUT FROM CONNECTOR.** PRESS IN RUBBER SEAL ON HARNESS INTO CONNECTOR HOUSING. REASSEMBLE CONNECTOR **A24** AND PLACE BACK ONTO ECM.

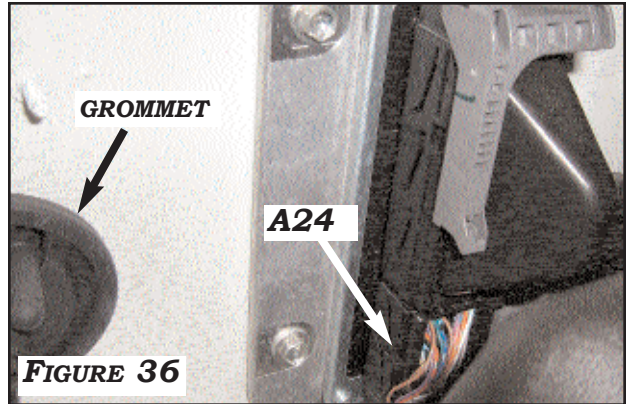


4. REPEAT TESTING PROCEDURE.

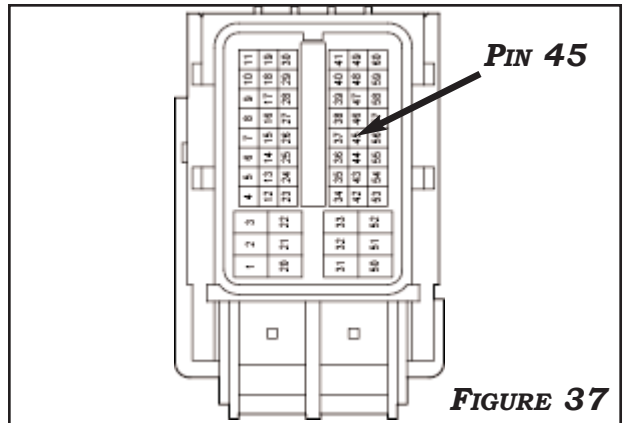
## REASSEMBLY



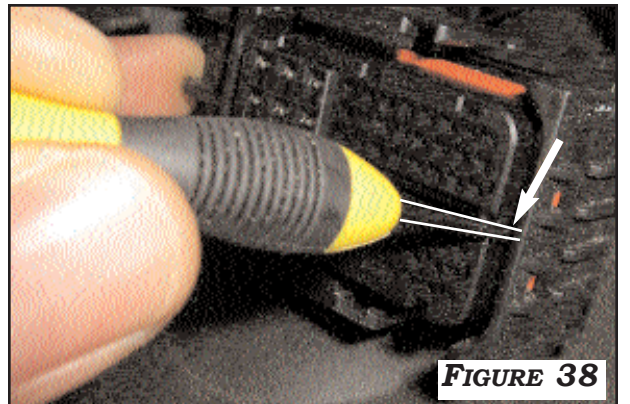
1. REINSTALL TRIM PIECES TAKING SPECIAL CARE TO ENSURE HARNESSES AND WIRING CONNECTIONS ARE PROPERLY SECURED.
2. BE SURE HARNESS IS NOT PINCHED OR BOUND.



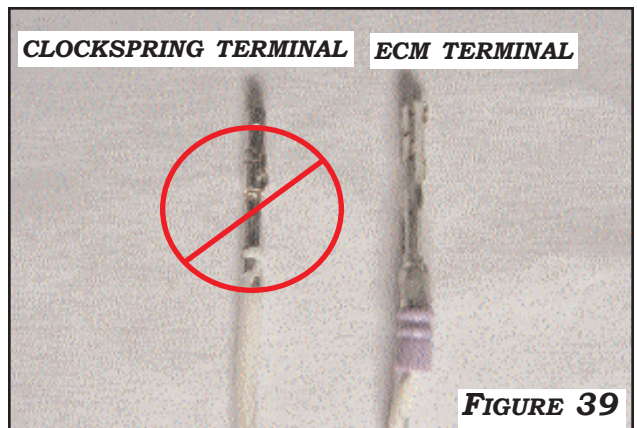
**FIGURE 36**



**FIGURE 37**



**FIGURE 38**

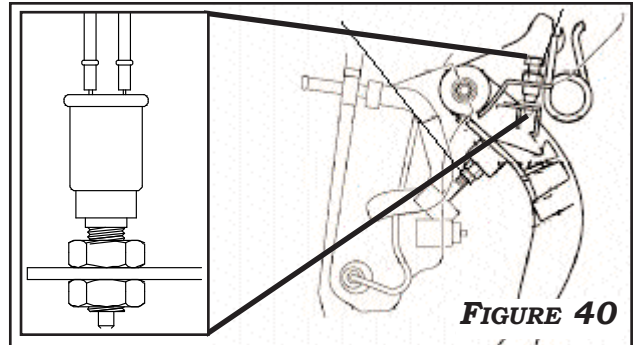


**FIGURE 39**

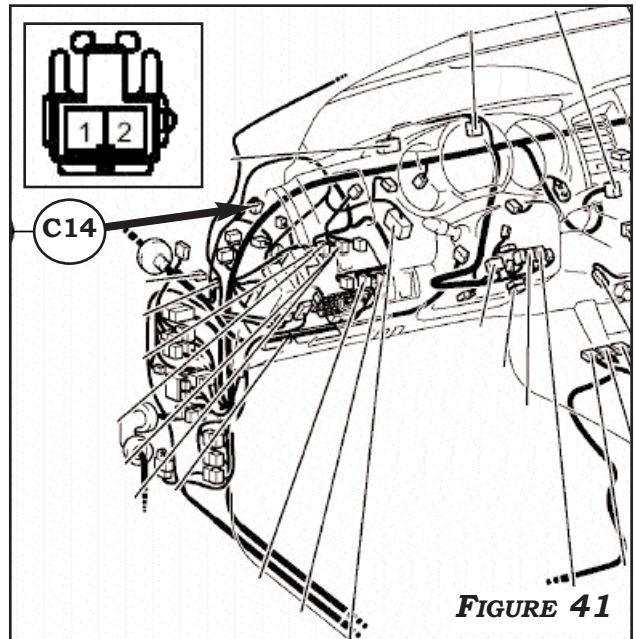
# TACOMA INSTALLATION

**NOTE**  
**FOR MANUAL TRANSMISSION TACOMA, ROSTRA CLUTCH DISENGAGEMENT SWITCH AND CLUTCH HARNESS KIT 250-2663 IS REQUIRED.**

**A. FOR MANUAL TRANSMISSION TACOMA ONLY:** REPLACE CLUTCH PEDAL STOP BOLT WITH ROSTRA CLUTCH DISENGAGEMENT SWITCH. ATTACH CLUTCH HARNESS TO CLUTCH DISENGAGEMENT SWITCH. **FIGURE 40**



**B. FOR MANUAL TRANSMISSION TACOMA ONLY:** LOCATE CONNECTOR **C14** ABOVE CLUTCH PEDAL, **FIGURE 41**, AND ATTACH **RED** T-TAPS TO THE **Lt. BLUE** AND **Lt. GREEN** WIRES. CONNECT MALE TERMINALS TO **VIOLET** WIRES OF CLUTCH HARNESS AND MAKE CONNECTION WITH THE T-TAPS PREVIOUSLY INSTALLED.



# PRIUS INSTALLATION



**CAUTION:** ENSURE THAT BATTERY HAS BEEN DISCONNECTED FOR MORE THAN 90 SECONDS PRIOR TO REMOVAL OF AIRBAG; FAILURE TO HEED THIS WARNING MAY RESULT IN AIRBAG DISCHARGE AND MAY CAUSE SERIOUS INJURY OR DEATH.



PRIOR TO REMOVAL OF AIRBAG; FAILURE TO HEED THIS WARNING MAY RESULT IN AIRBAG DISCHARGE AND MAY CAUSE SERIOUS INJURY OR DEATH.

## STOP SWITCH ASSEMBLY



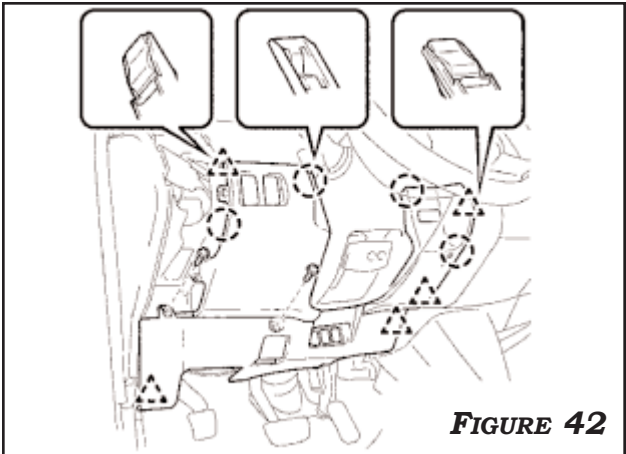
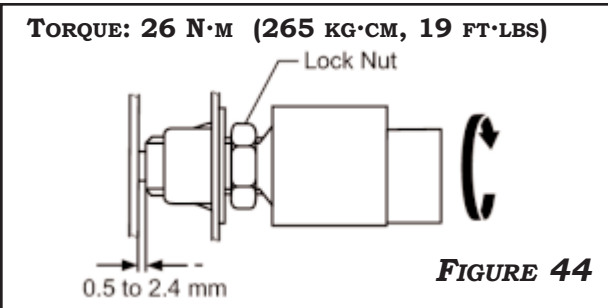
1. ENSURE BATTERY IS DISCONNECTED ACCORDING TO PAGE 2.
2. PULL UP THE FLOOR CARPET AND DASH PANEL INSULATOR. REMOVE 2 SCREWS AND DETACH CLIPS TO RELEASE THE LOWER INSTRUMENT PANEL FINISH PANEL AS SHOWN IN **FIGURE 42**.
3. LOCATE THE BLACK STOP LIGHT SWITCH ASSEMBLY **S16** SHOWN IN **FIGURE 43**. DISCONNECT THE CONNECTOR FROM THE STOP LIGHT SWITCH. RECORD THE POSITION OF THE **14MM** NUT ON THE STOP LIGHT SWITCH ASSEMBLY THREADS. REMOVE THE EXISTING STOP LIGHT SWITCH ASSEMBLY FROM CONNECTOR AND DISCARD.
4. REPLACE SWITCH WITH THE STOP LIGHT SWITCH ASSEMBLY SUPPLIED IN KIT USING THE PREVIOUSLY RECORDED NUT POSITION. TURN THE STOP LIGHT SWITCH SO THAT THE CLEARANCE BETWEEN ITS THREAD PORTION TIP AND THE AREA WHERE THE PEDAL MAKES CONTACT IS BETWEEN 0.5 TO 2.4 MM (0.020 TO 0.095 IN.). **TORQUE: 26 N·M (265 KG·CM, 19 FT·LBS).** **FIGURE 44**. CONNECT THE CONNECTOR TO THE STOP LIGHT SWITCH ASSEMBLY.

**NOTE:** FOR 09 & UP PRIUS VEHICLES, IF APPLICABLE, USE THE STOP LIGHT SWITCH HARNESS SUPPLIED IN KIT TO CONNECT FROM THE STOP LIGHT SWITCH ASSEMBLY TO THE BLACK CONNECTOR OF THE VEHICLE STOP LIGHT SWITCH HARNESS AS SHOWN IN **FIGURE 45**.

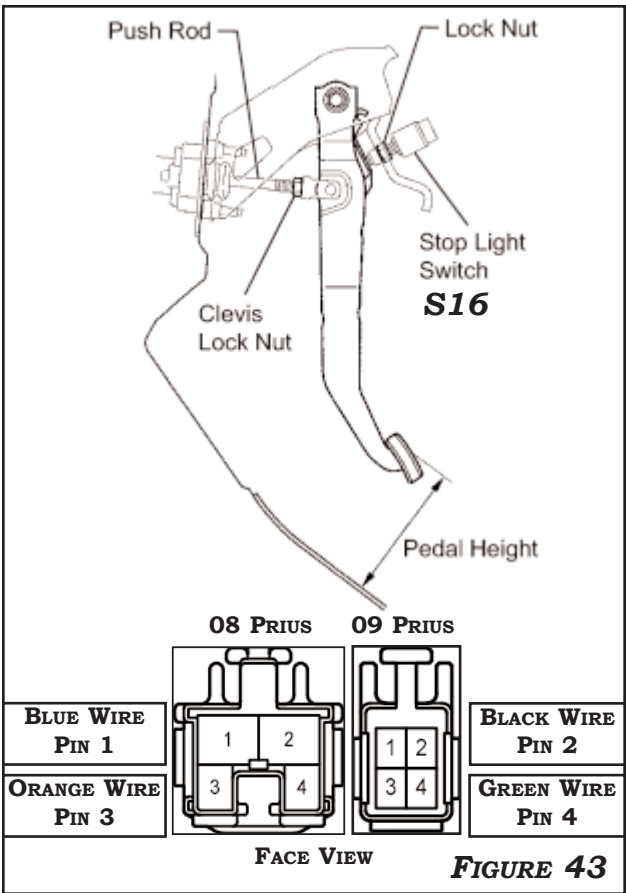
## REASSEMBLY



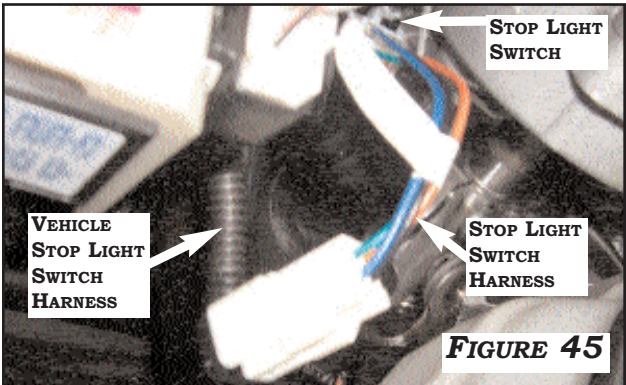
1. REINSTALL TRIM PIECES TAKING SPECIAL CARE TO ENSURE HARNESES AND WIRING CONNECTIONS ARE PROPERLY SECURED.
2. BE SURE HARNESES ARE NOT PINCHED OR BOUND.



**FIGURE 42**



**FIGURE 43**



**FIGURE 45**

# YARIS VEHICLE PREPARATION

## VEHICLE PREPARATION:

1. DISCONNECT THE CABLE FROM THE NEGATIVE TERMINAL OF THE BATTERY. **FIGURE 1**



**CAUTION:** ENSURE THAT BATTERY HAS BEEN DISCONNECTED FOR MORE THAN 90 SECONDS PRIOR TO REMOVAL OF AIRBAG; FAILURE TO HEED THIS WARNING MAY RESULT IN AIRBAG DISCHARGE AND MAY CAUSE SERIOUS INJURY OR DEATH.

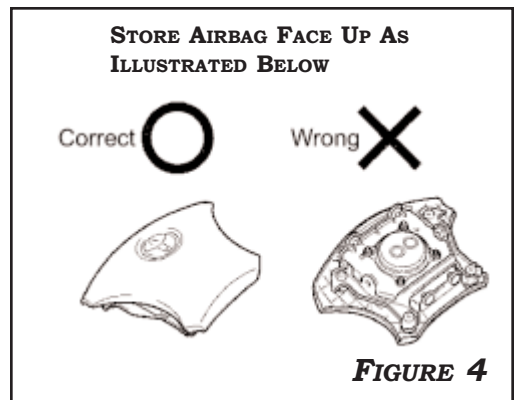
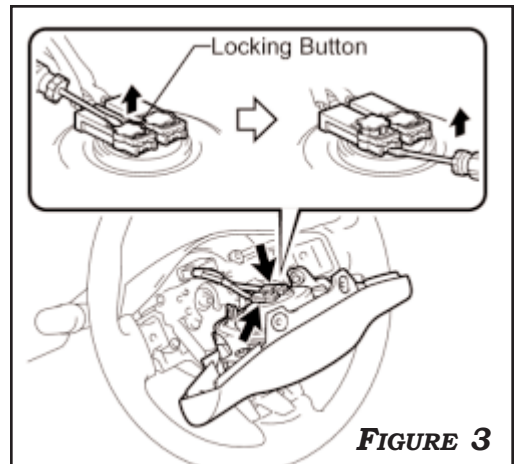
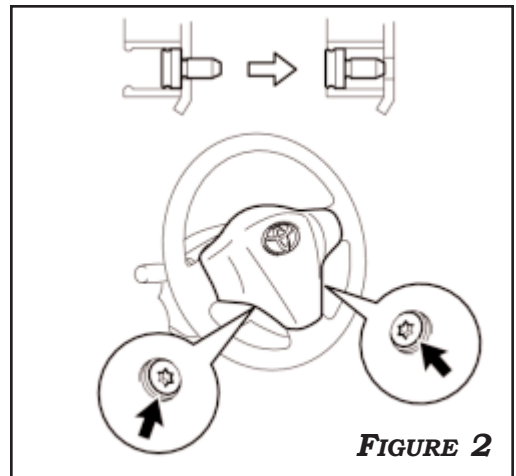
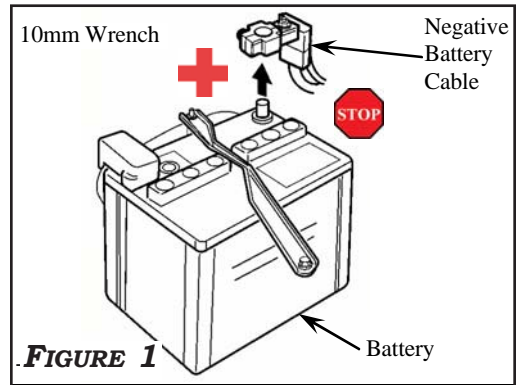


2. REMOVE AIRBAG BY EXTRACTING THE TWO 30 TORX SCREWS AS ILLUSTRATED IN **FIGURE 2**.

3. REMOVE GROUND TERMINAL AND DUMMY HORN/CRUISE CONNECTOR FROM STEERING WHEEL AND DISCARD. UTILIZE SMALL SCREWDRIVER TO REMOVE AIRBAG CONNECTORS AS ILLUSTRATED IN **FIGURE 3**.



**CAUTION:** BE SURE TO STORE AIRBAG FACE UP AS ILLUSTRATED IN **FIGURE 4** TO REDUCE INJURY IN EVENT OF ACCIDENTAL DISCHARGE OF AIRBAG.



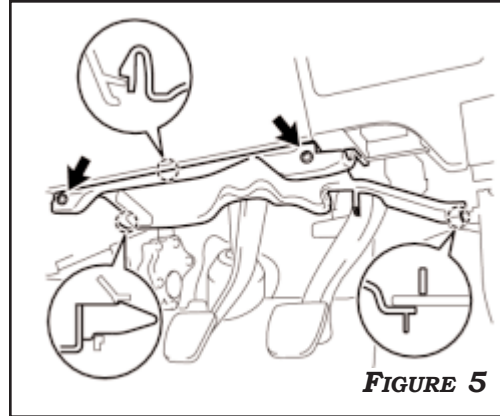
# YARIS VEHICLE PREPARATION

## VEHICLE PREPARATION

(FOR VEHICLES WITH MANUAL TRANSMISSION)

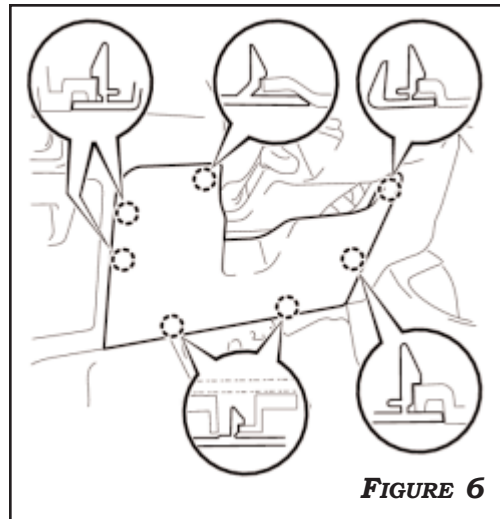


4. REMOVE 2 SCREWS AND DISENGAGE THE 3 CLAWS TO REMOVE THE INSTRUMENT PANEL UNDER COVER **FIGURE 5**



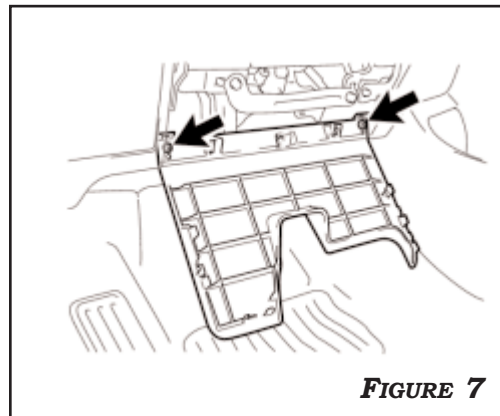
**FIGURE 5**

5. DISENGAGE THE 7 CLAWS AND OPEN THE INSTRUMENT PANEL LOWER FINISH PANEL. **FIGURE 6**



**FIGURE 6**

6. REMOVE THE 2 SCREWS AND REMOVE THE INSTRUMENT PANEL LOWER FINISH PANEL. **FIGURE 7**



**FIGURE 7**

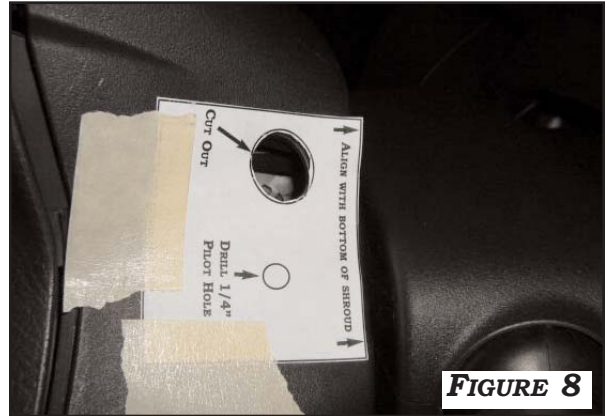
# YARIS INSTALLATION

## CONTROL SWITCH



**1. FOR DIO INSTALLS:** USE THE **SWITCH HOLE CUTTING TEMPLATE** ON PAGE 19, PLACE THE TEMPLATE ON THE RIGHT SIDE OF THE STEERING SHROUD AS SHOWN AND DRILL TWO A (1/4") PILOT HOLE. **FIGURE 8.** CONTINUE TO STEP 4.

**2.** REMOVE YARIS SWITCH HOLE CUTTING TEMPLATE. USE A 1 1/8" HOLE SAW TO DRILL SWITCH HOLE. **FIGURE 9.**

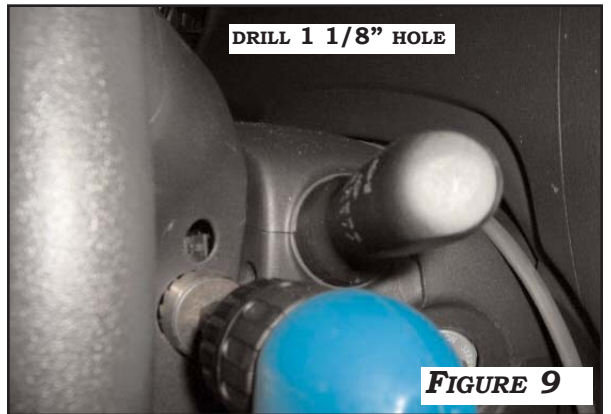


**FIGURE 8**



**3.** MOUNT CRUISE CONTROL SWITCH WITH TWO (2) PHILLIPS SCREWS PROVIDED. REMOVE GROUND TERMINAL AND DUMMY HORN/CRUISE CONNECTOR FROM STEERING WHEEL AND DISCARD. PLUG IN CRUISE SWITCH CONNECTOR ENSURING TO RECONNECT GROUND TERMINAL. **FIGURES 10-11**

**4.** IF VEHICLE HAS MANUAL TRANSMISSION, SKIP TO NEXT PAGE. IF VEHICLE HAS AUTOMATIC TRANSMISSION, CONTINUE TO THE TESTING SECTION BELOW.



**FIGURE 9**

## TESTING

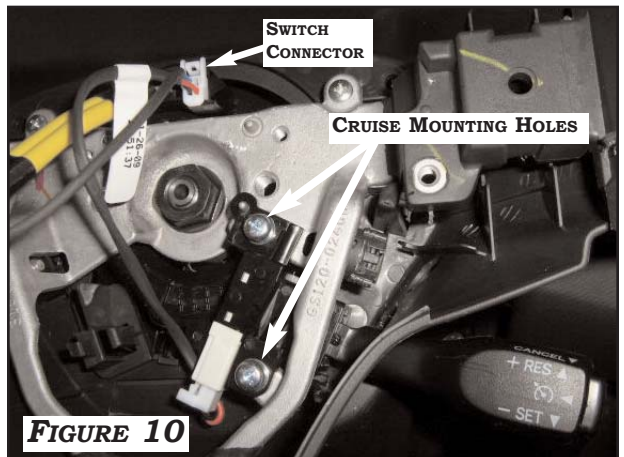


**1.** REINSTALL AIRBAG. TORQUE SCREWS TO 78 IN. LBS.

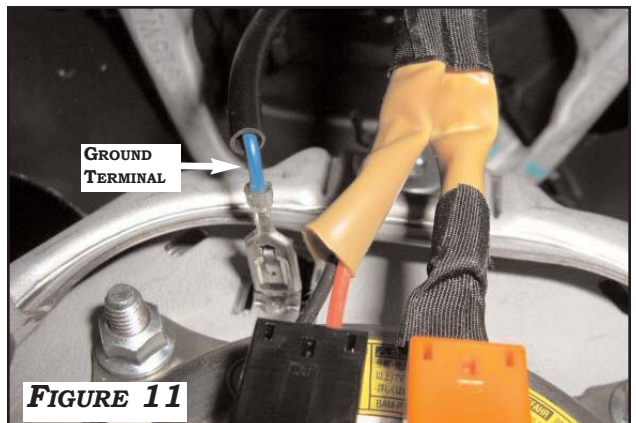


**2.** RECONNECT NEGATIVE BATTERY CABLE AND TORQUE TO 3 FT\*LBS.

**3.** TURN THE IGNITION TO THE "ON" POSITION. PRESS THE "CRUISE ON-OFF" BUTTON. THIS OPERATION TURNS THE SYSTEM ON. THE INDICATOR LIGHT IN THE INSTRUMENT PANEL WILL COME ON. IF THIS LIGHT COMES ON, SEE THE OPERATING INSTRUCTIONS. IF THE LIGHT DOES NOT COME ON, COMPLETE INSTALLATION USING SMALL PARTS PACKAGE.



**FIGURE 10**



**FIGURE 11**

# YARIS INSTALLATION

**NOTE**  
**FOR MANUAL TRANSMISSION YARIS, USE ROSTRA CLUTCH DISENGAGEMENT SWITCH AND CLUTCH HARNESS KIT 250-2663 IS REQUIRED.**

**1. FOR MANUAL TRANSMISSION YARIS ONLY:** RECORD THE STOP BOLT POSITION ON THE CLUTCH PEDAL. USE A **14MM** WRENCH TO REMOVE. REPLACE CLUTCH PEDAL STOP BOLT WITH ROSTRA CLUTCH DISENGAGEMENT SWITCH. ATTACH CLUTCH HARNESS TO CLUTCH DISENGAGEMENT SWITCH. **FIGURES 12-13**

**2. FOR MANUAL TRANSMISSION YARIS ONLY:** LOCATE CONNECTOR **A29** BETWEEN THE JUNCTION BOX AND BRAKE SWITCH. **FIGURE 14.** **NOTE: IF CONNECTOR IS NOT PRESENT, GO TO NEXT PAGE.** CONNECT ONE OF THE TWO **VIOLET WIRES** FROM THE CLUTCH DISENGAGEMENT SWITCH TO THE **BLACK** WIRE IN **PIN 1** OF CONNECTOR **A29**. CONNECT THE OTHER **VIOLET WIRE** TO THE **BLUE** IN **PIN 2** OF CONNECTOR **A29**. SECURE CLUTCH SWITCH HARNESS WITH WIRE TIES.

## TESTING

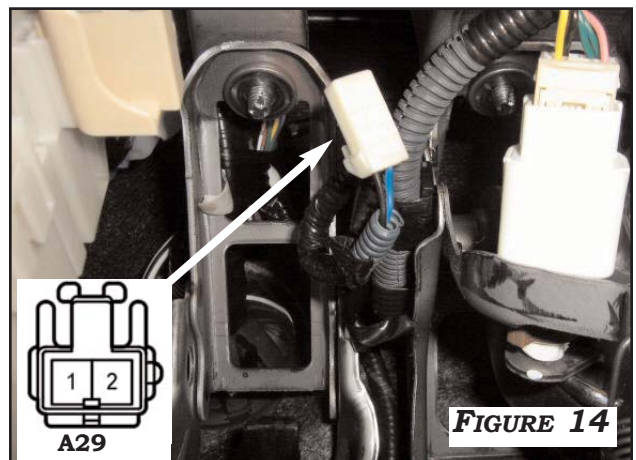
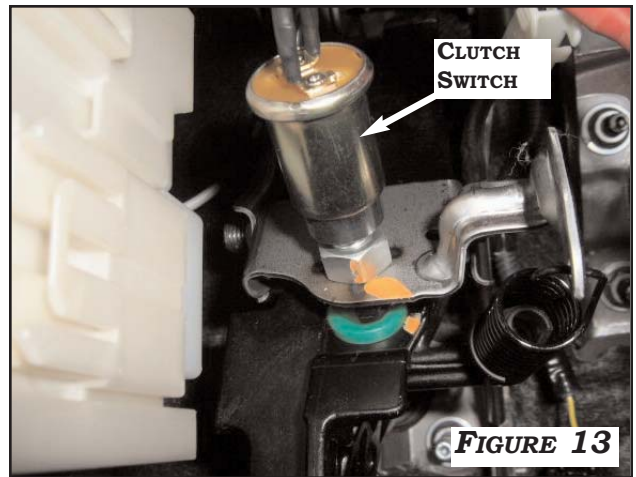
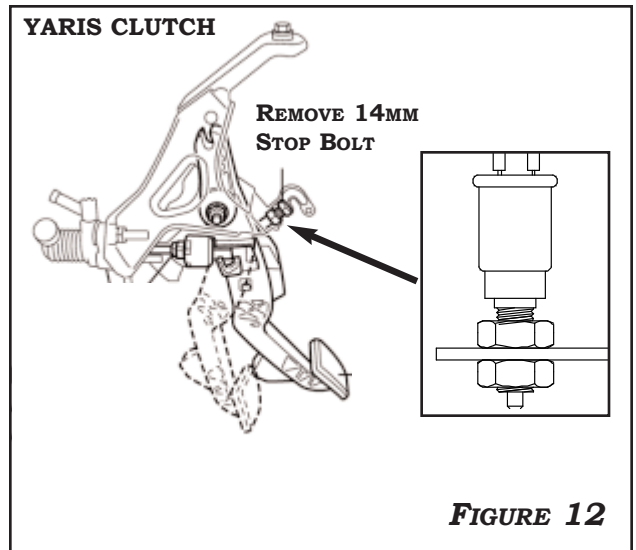


**1. REINSTALL AIRBAG.** TORQUE SCREWS TO 78 IN. LBS.



**2. RECONNECT NEGATIVE BATTERY CABLE AND TORQUE TO 3 FT\*LBS.**

**3. TURN THE IGNITION TO THE "ON" POSITION.** PRESS THE "CRUISE ON-OFF" BUTTON. THIS OPERATION TURNS THE SYSTEM ON. THE INDICATOR LIGHT IN THE INSTRUMENT PANEL WILL COME ON. IF THIS LIGHT COMES ON, SEE THE OPERATING INSTRUCTIONS. IF THE LIGHT DOES NOT COME ON, COMPLETE INSTALLATION USING SMALL PARTS PACKAGE.







# YARIS INSTALLATION USING SACK PART OF 250-1731



**CAUTION: ENSURE THAT BATTERY HAS BEEN DISCONNECTED FOR MORE THAN 90 SECONDS PRIOR TO REMOVAL OF AIRBAG; FAILURE TO HEED THIS WARNING MAY RESULT IN AIRBAG DISCHARGE AND MAY CAUSE SERIOUS INJURY OR DEATH.**



## STEERING WHEEL WIRE ROUTING

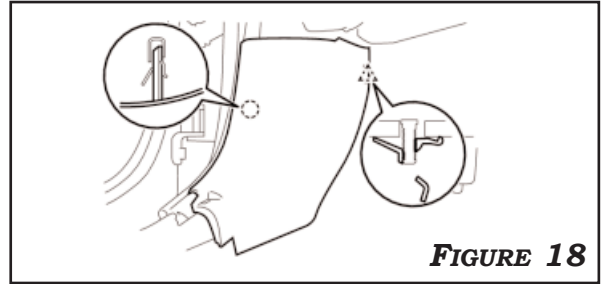


1. REMOVE DRIVER SIDE KICK PANEL AND SCUFF PLATE. **FIGURE 18**. REMOVE THE 2 SCREWS AND REMOVE THE INSTRUMENT PANEL LOWER FINISH PANEL. **FIGURE 19**.

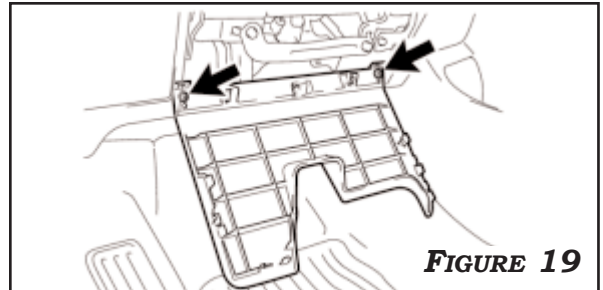
2. REMOVE 2 SCREWS AND REMOVE THE STEERING WHEEL SHROUD COVER. **FIGURE 20**

3. LOCATE BLACK ECM CONNECTOR **A21** IN THE ENGINE COMPARTMENT ON THE PASSENGER SIDE FIREWALL. **FIGURE 21** REMOVE CONNECTOR AND WIRE COVER. LOCATE BLACK CRUISE ECM HARNESS IN SACK PART. INSERT TERMINAL WITH PURPLE SEAL INTO PIN **40**(CRUISE CIRCUIT) OF CONNECTOR **A21**. IF BLUE WIRE IS PRESENT, **CUT OFF TERMINAL END WITH PURPLE SEAL**. CONNECT BLACK CRUISE ECM WIRE TO **BLUE WIRE PIN 40**(CRUISE CIRCUIT) OF CONNECTOR **A21**. **FIGURES 22-23**

4. ROUTE THE CRUISE ECM WIRE TO THE STEERING WHEEL AREA ALONG THE EXISTING VEHICLE WIRING. **NOTE: THE CRUISE ECM WIRE WILL MAY REQUIRE ADDING WIRE TO EXTEND TO STEERING WHEEL.**



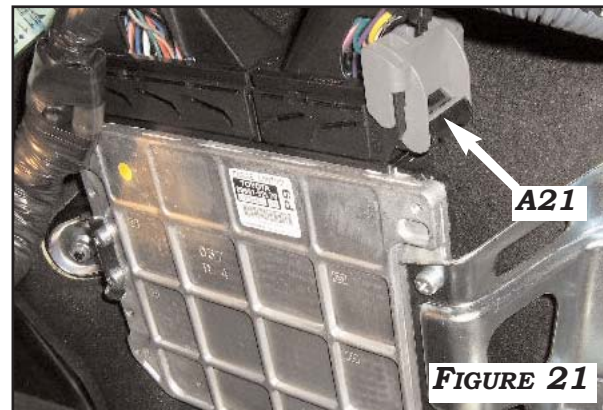
**FIGURE 18**



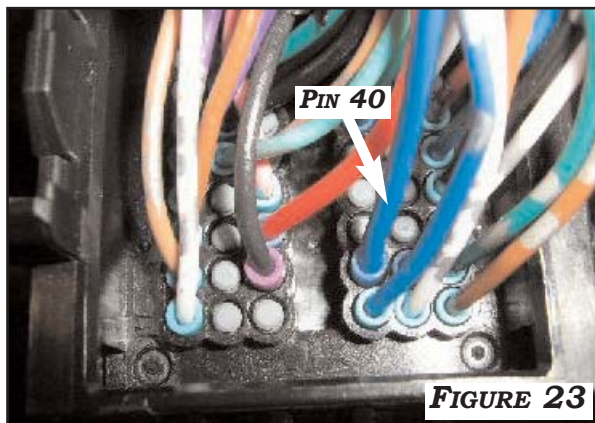
**FIGURE 19**



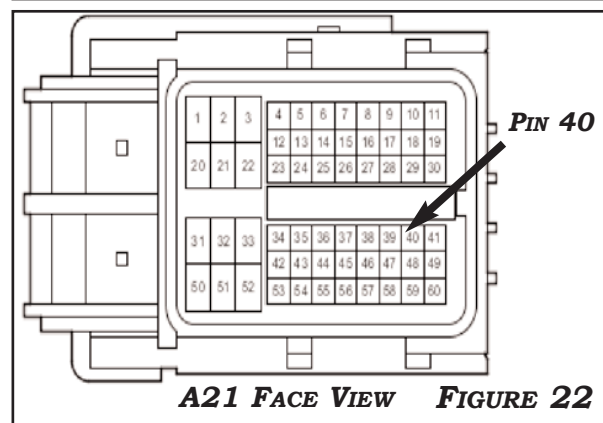
**FIGURE 20**



**FIGURE 21**



**FIGURE 23**



**A21 FACE VIEW FIGURE 22**

# YARIS INSTALLATION USING SACK PART OF 250-1731

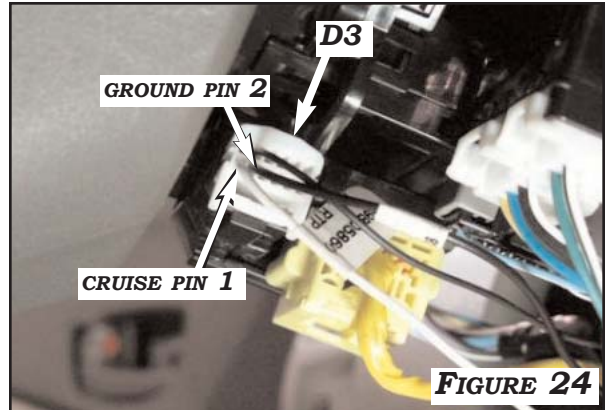
## STEERING WHEEL WIRE ROUTING



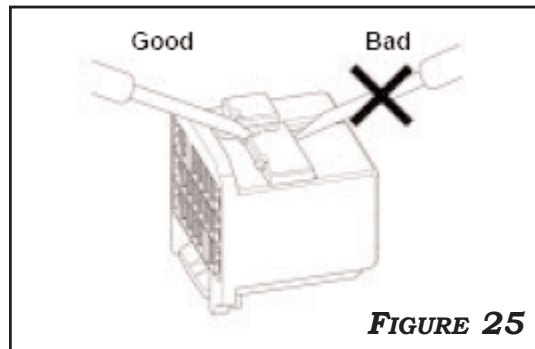
5. LOCATE WHITE CONNECTOR **D3** BEHIND STEERING WHEEL AT RIGHT SIDE OF SUB ASSEMBLY. **FIGURE 24**. REMOVE CONNECTOR. **BE SURE TO PULL OUT TERMINAL RETAINER AT THE CENTER OF CONNECTOR. FIGURE 25.** INSERT THE **D3 TERMINAL** FROM THE CRUISE ECM WIRE TO **PIN 1** (CRUISE CIRCUIT) OF CONNECTOR **D3. FIGURES 25-26.**

6. INSERT THE **D3 TERMINAL** FROM CRUISE GROUND WIRE INTO PIN **2** (CRUISE GROUND) OF CONNECTOR **D3** CAREFULLY LOCKING TERMINAL INTO PLACE. **FIGURES 26-27.** PULL THE TERMINALS BACK GENTLY TO CHECK WHETHER IT IS LOCKED CORRECTLY. **FIGURE 26.** REASSEMBLE CONNECTOR AND PLACE BACK ONTO SUB ASSEMBLY. **BE SURE RETAINER IS PRESSED IN BEFORE REINSTALLING.**

7. ROUTE THE GROUND WIRE ALONG THE FACTORY HARNESS TO THE 10MM BOLT AT **GROUND POINT D1** AS SHOWN IN **FIGURE 28.** REMOVE THE 10MM BOLT AND INSTALL THE RING TERMINAL FROM THE CRUISE GROUND WIRE. **SECURE THE HARNESSES WITH WIRE TIES.**



**FIGURE 24**



**FIGURE 25**

## TESTING

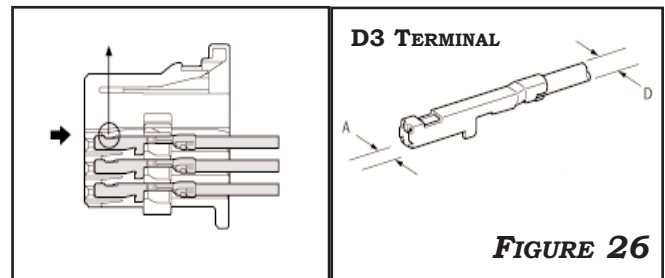


1. REINSTALL AIRBAG. TORQUE SCREWS TO 78 IN. LBS.

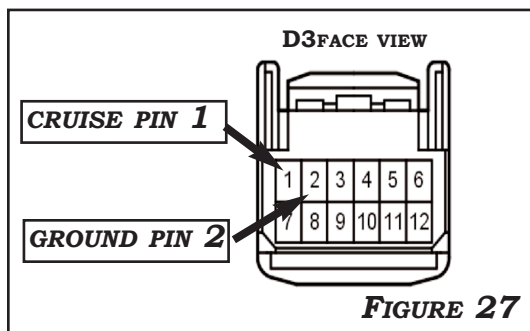


2. RECONNECT NEGATIVE BATTERY CABLE AND TORQUE TO **3 FT\*LBS.**

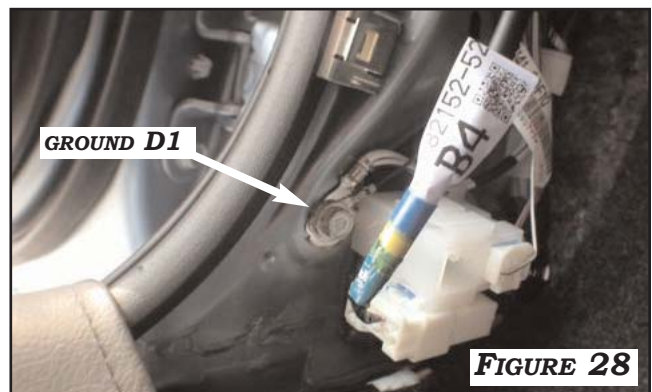
3. TURN THE IGNITION TO THE "ON" POSITION. PRESS THE "CRUISE ON-OFF" BUTTON. THIS OPERATION TURNS THE SYSTEM ON. THE INDICATOR LIGHT IN THE INSTRUMENT PANEL WILL COME ON. NOTE: SOME 08 YEAR MODEL VEHICLES DO NOT HAVE A CRUISE INDICATOR LIGHT IN DASH. TEST WITH A MULTI-METER FOR 12 VOLTS IGNITION POWER BETWEEN PINS 1 & 2 OF CLOCKSPRING CONNECTOR. IF VOLTAGE IS PRESENT, TEST DRIVE VEHICLE FOR CRUISE OPERATION.



**FIGURE 26**



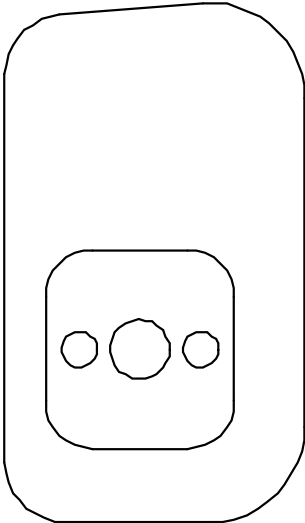
**FIGURE 27**



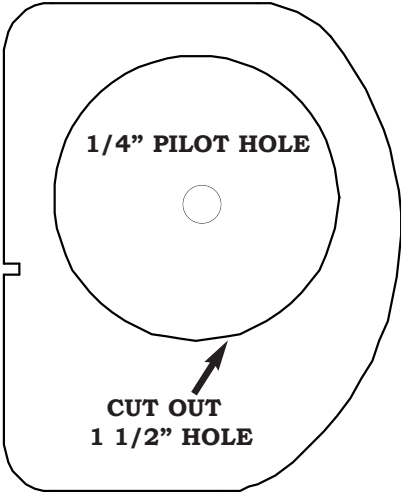
**FIGURE 28**

# TEMPLATES

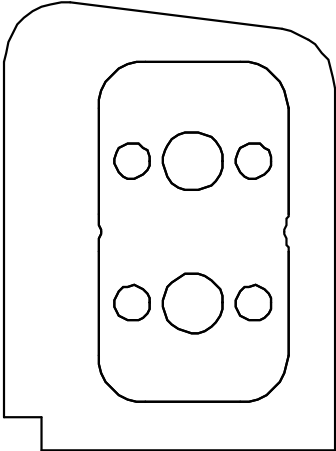
**COROLLA TEMPLATE**



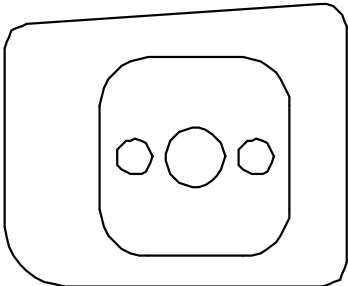
**TACOMA TEMPLATE**



**PRIUS TEMPLATE**



**TUNDRA TEMPLATE**



**YARIS TEMPLATE**

