

2010 FORD TRANSIT

Part Number: 250-1857

ELECTRONIC CRUISE KIT

AUTOMATIC AND MANUAL TRANSMISSION

General Applicability

--

Item #	Qty.	Description
1. 250-2758	1	Cruise Control Module
2. 250-2760	1	Switch Harness
3. 250-2759	1	Main Wiring Harness
4. 250-2771	1	Pedal Interface Harness
5. 250-2772	1	Hardware Kit
6. 250-3742	1	Control Switch

Kit Contents/Service Parts

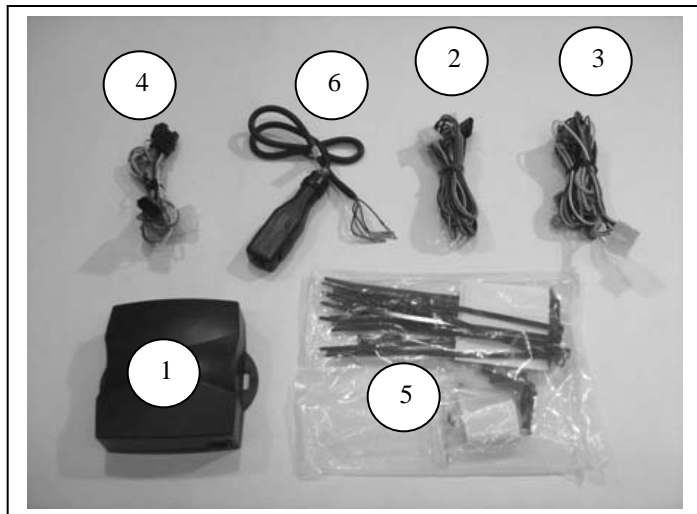

Contents of Hardware Bag, 250-2772

Qty	Description
4	Foam Tape
8	Wire Zip Ties
6	Posi-Taps
1	Weather Sealant

Additional Items Required For Installation

Recommended Tools

Safety Tools	
Gloves, Safety Glasses	
Special Tools	
Volt-Ohm Meter	
Installation Tools	
Side cutter	To cut wire ties
Drill Bit or Knockout Punch	9.5mm or 3/8" (for switch)
10mm wrench	
Special Chemicals	

Conflicts

Note:

Recommended Sequence of Application

Item #	Accessory	
1		
2		
3		

Legend

	STOP: Damage to the vehicle may occur. Do not proceed until process has been complied with.
	OPERATOR SAFETY: Use caution to avoid risk of injury
	CRITICAL PROCESS: Proceed with caution to ensure a quality installation.
	GENERAL PROCESS: This highlights specific processes to ensure a quality installation.
	TOOLS & EQUIPMENT: This calls out the specific tools and equipment required for this process

2010 FORD TRANSIT

Part Number: 250-1857

Section I – Installation Procedure

ELECTRONIC CRUISE KIT

AUTOMATIC AND MANUAL TRANSMISSION

A. Pre-Installation Suggestions



1. It is advisable to disconnect the negative battery cable for 3 minutes before beginning installation, to avoid unintended air bag deployment. Note and record any anti-theft radio codes prior to disconnecting. **Figure 1**



2. Remove the driver side lower dash and kick panels. Remove the steering wheel shroud. **Figure 2**

➔ B. Install Electronic Module



1. Plug in the **Main Wiring Harness, Switch Harness, and Pedal Interface Harness** onto mating connectors of the **Cruise Control Module**. **Figure 3**
2. Place the **Cruise Control Module** in a secure location behind the driver side dash area near the firewall away from moving parts and secure with zip ties.
3. Route the **Pedal Interface Harness** through steering column and down to the accelerator.

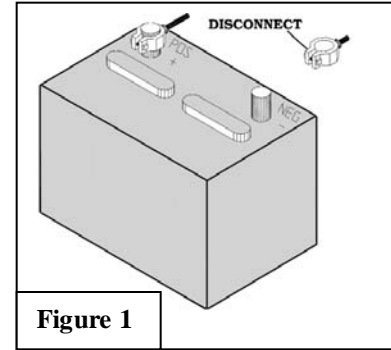

Figure 1

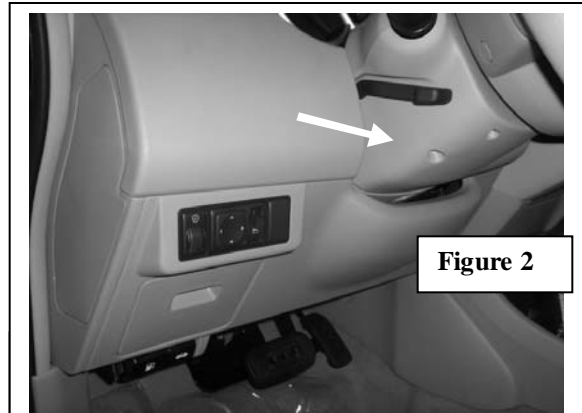

Figure 2



Figure 3

2010 FORD TRANSIT

Part Number: 250-1857

ELECTRONIC CRUISE KIT

AUTOMATIC AND MANUAL TRANSMISSION

➔ C. Install Pedal Interface Harness

1. Use the diagram and chart below to install the pedal interface harness. Disconnect the Pedal Interface Harness at the 2-pin connectors to ease installation of Posi-tap connections.

Figure 4. Remove the cap from the Posi-tap connector. Insert each wire in the groove of the connector as shown in **Figure 5**. **Be sure the pin is centered on the wire when pin contacts the wire. Keep the Posi-tap straight to do this.** Screw on the cap by hand until the wire is tightly tapped. Cut the accelerator harness between the two Posi-tap connectors of each selected wire location.

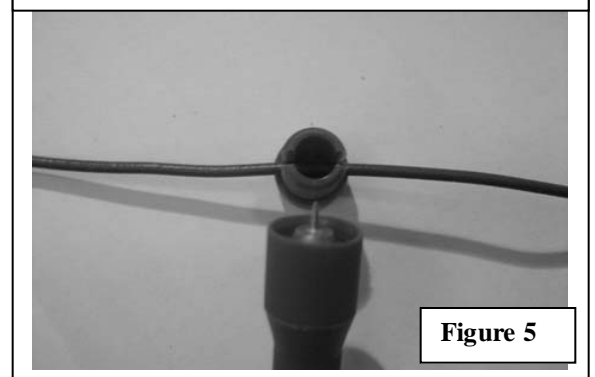
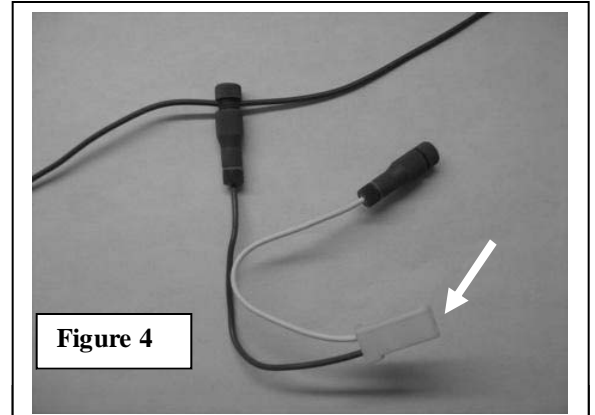

TRANSIT CONNECTIONS

WARNING: PROCEED WITH CAUTION TO BE SURE PEDAL INTERFACE HARNESS IS MATED PROPERLY TO THE ACCELERATOR HARNESS. FAILURE TO DO THIS CORRECTLY WILL DISABLE THE ACCELERATOR.

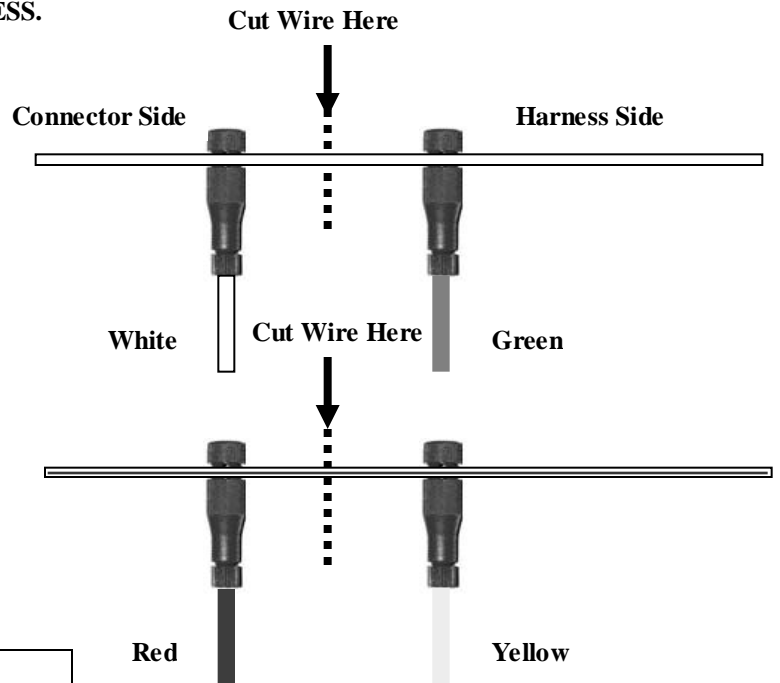
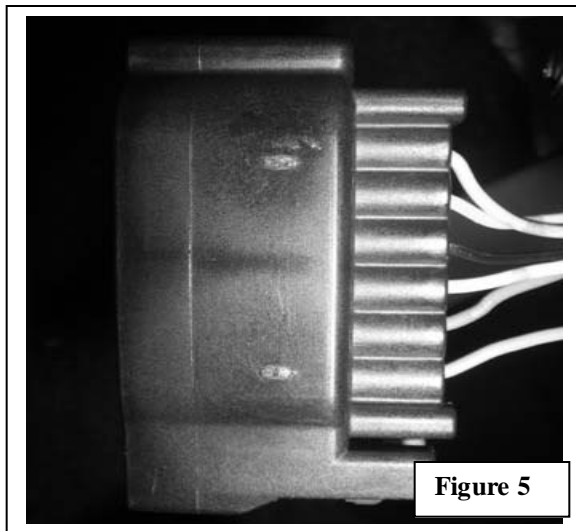

Posi-Tap Direction	Cruise Harness Color	Vehicle Wire
CONNECTOR	RED	WHITE/RED
CONNECTOR	WHITE	WHITE
HARNESS	YELLOW	WHITE/RED
HARNESS	GREEN	WHITE

2. Before continuing cruise installation, plug in the mating 2-pin connectors from the Posi-tap connections. Doing this will ensure proper wiring connections on the accelerator harness. Reconnect negative side of battery. Start engine and press accelerator to confirm operation. Turn off engine and Disconnect battery. **Figure 6**

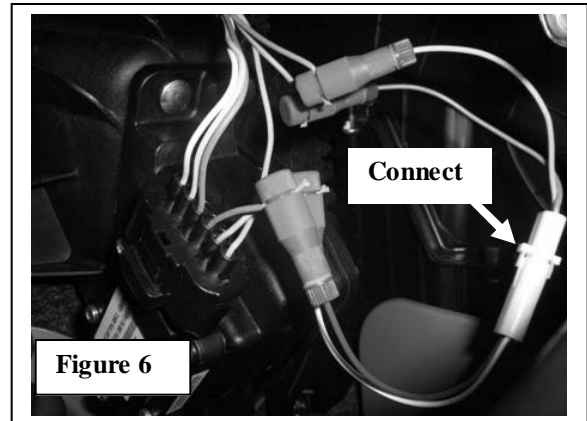

Figure 6

3. Disconnect Posi-tap harnesses at the 2-pin connectors and reconnect to Pedal Interface Harness at the mating connectors. Use the foam tape supplied in kit to wrap all connections. **Figure 7**

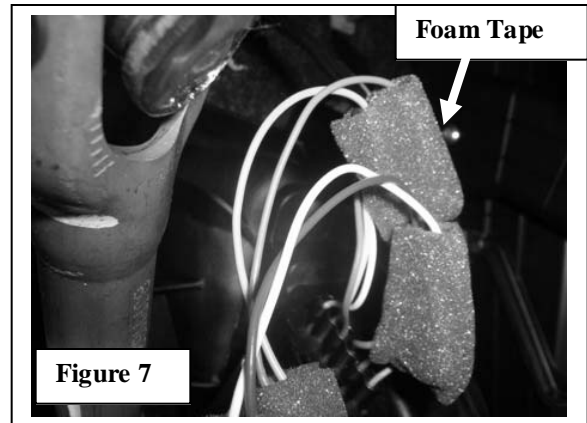
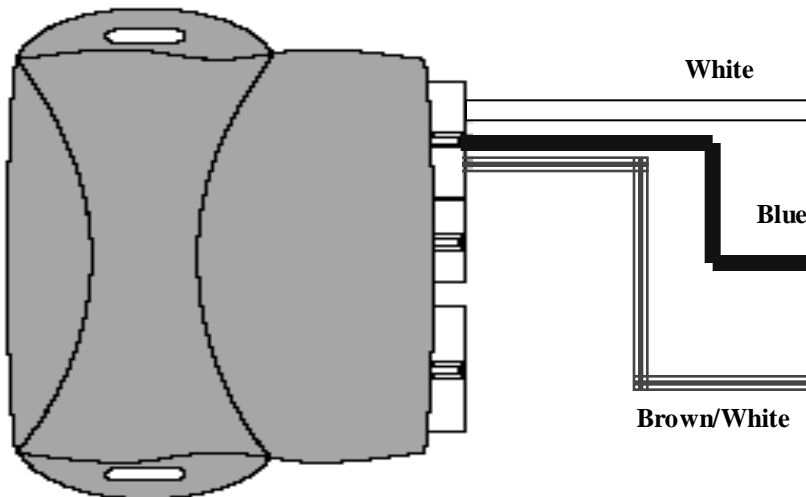

Figure 7

➔ D. Wiring Connections



1. Use the following wiring diagram as a reference to connect cruise to the vehicle:



Clutch: Connect to ground or +12v active wire when clutch is pressed.

Brake positive: Connect to hot side of brake. Constant +12v brake wire

Brake negative: Connect to cold side of brake. +12v when brake is pressed.

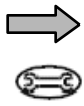

E. Wiring Connections

1. Use the following wiring diagram as a reference to connect cruise to the vehicle:

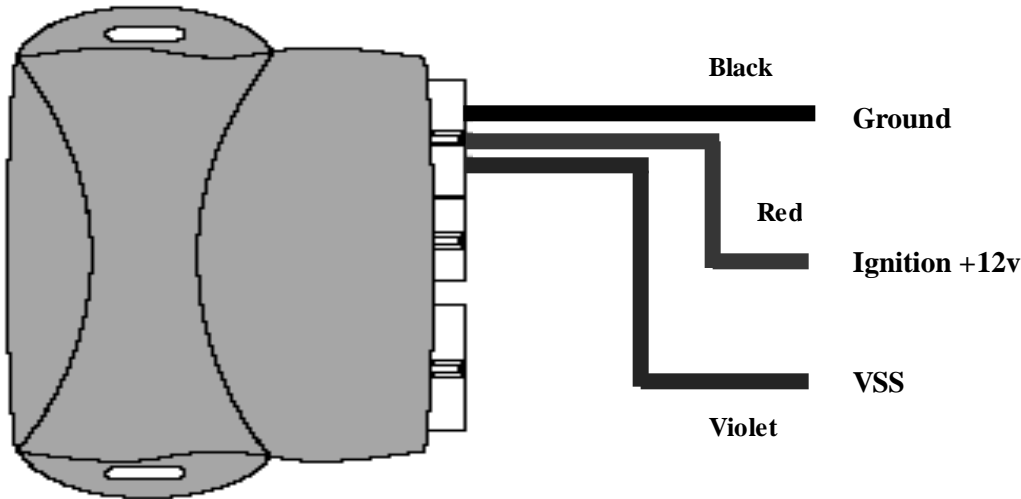

F. Wiring Connections

1. Use the supplied POSITAP connectors to connect from the Main Harness to vehicle wire.

Function	Cruise Harness Color	Vehicle Wire
IGN	RED	RED (figure 8)
BRAKE +	BLUE	GREEN/WHITE (fig 8)
BRAKE -	BROWN/WHITE	GREEN/WHITE (fig 8)
VSS	VIOLET	GREEN/WHITE (fig 12)
CLUTCH SWITCH	WHITE	PAGE 4

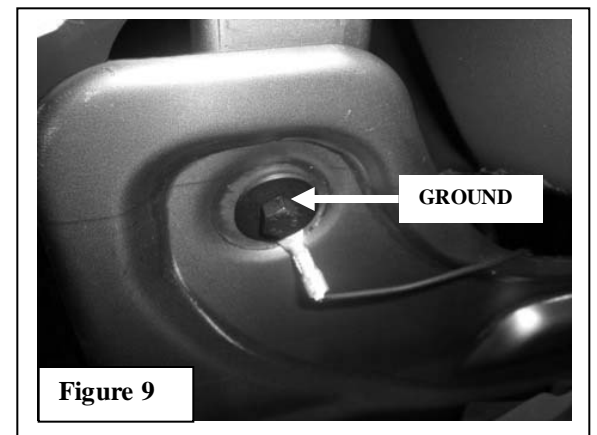
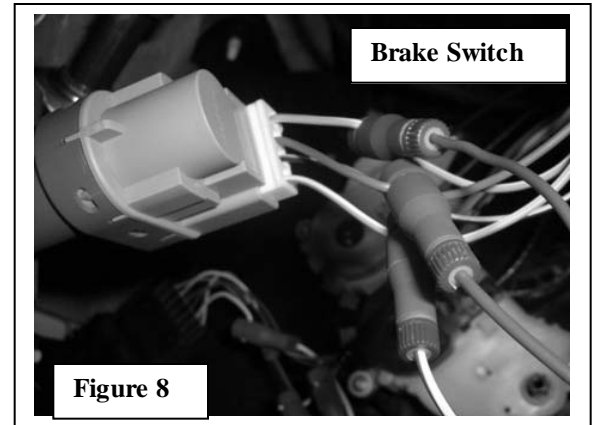

2. Apply the **Black Ground Wire** from the Main Harness to the Vehicle Ground Point at the lower dash frame panel. **Figure 9**

3. **VSS:** Locate the area center of the engine compartment between motor and firewall.
Figure 10. For reference, find the black metal bracket in front of the gray and blue connectors. **Figure 10.** Locate the gray 2-pin connector on the transmission below the bracket. **Figure 12.** Connect the **Violet Wire** from the cruise harness to **Green/White Wire (VSS)** of the connector. Be sure all of connection are tight so that they seal properly. **Figure 13**

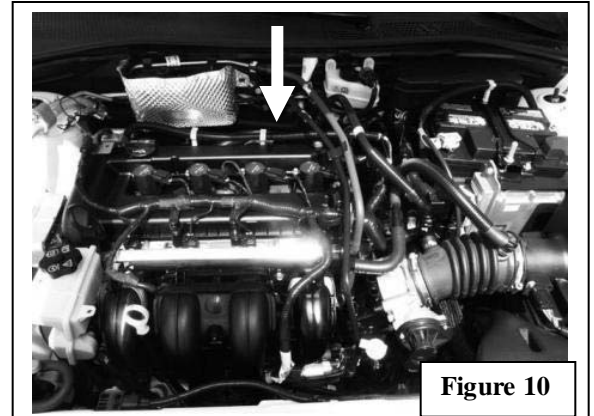

Figure 10

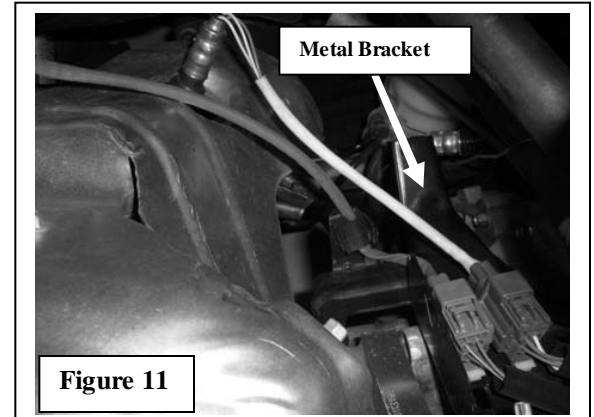

Figure 11

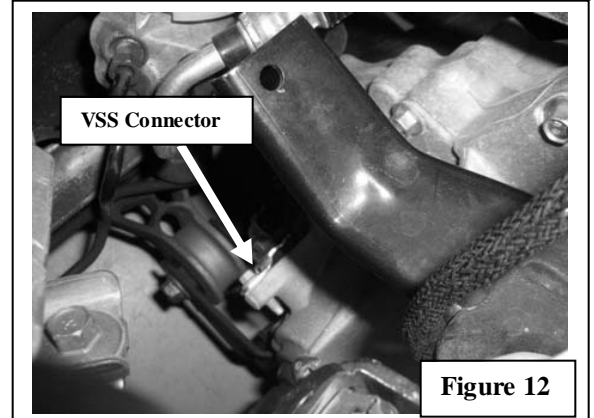

Figure 12

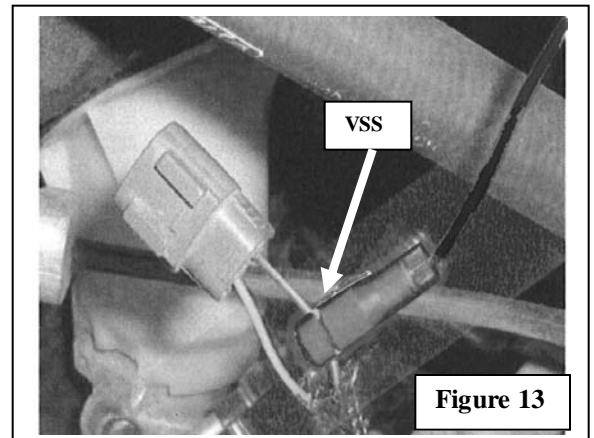

Figure 13



G. Install Control Switch

1. Use the **lever wedges** on the **Control Switch** at an angle template to drill a 3/8" or 9.5mm hole in the lower shroud of the steering column cover. Position lock-washers as shown. **Figure 14**
2. Apply nut and position **Control Switch** for driver's best view.
3. Assemble (2) 3-pin connectors from the sack parts to the mating wire colors on the **Control Switch Harness**. Use the diagram to mate the **module harness** to **switch harness**. **Figure 15**
4. Route the assembled **Control Switch Harness** to the mating connector of the Cruise Control module.
5. Secure the Control Switch harness with zip ties away from moving parts.

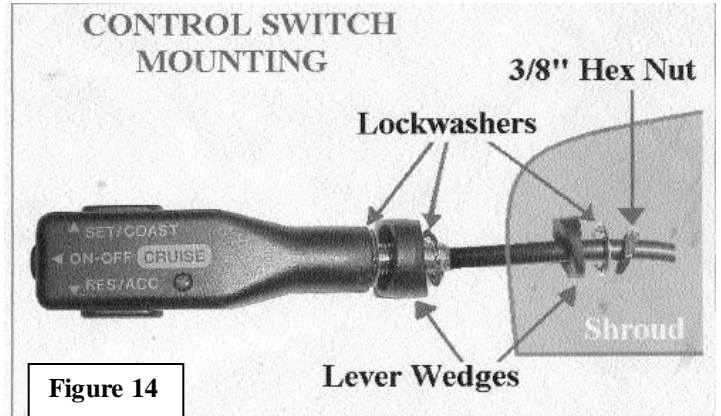

Figure 14



H. Testing

1. Reconnect negative battery cable and torque to 35 in*lbs. Reenter anti-theft radio codes.
2. Turn ignition on. Apply the on/off button of Cruise Control Switch.

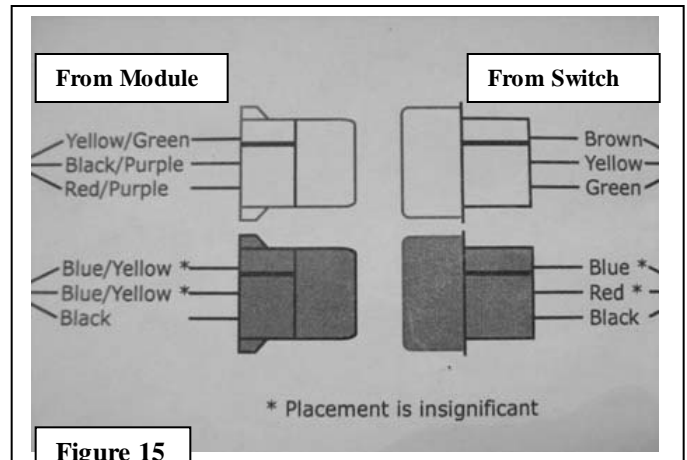

Figure 15



F. Reassembly

1. Reinstall all removed pieces taking care to ensure harnesses and wiring connections are properly secured.
2. Make sure all harnesses are not pinched or bound by trim pieces.



Switch Installed

Figure 16

Section II – Wiring Diagram

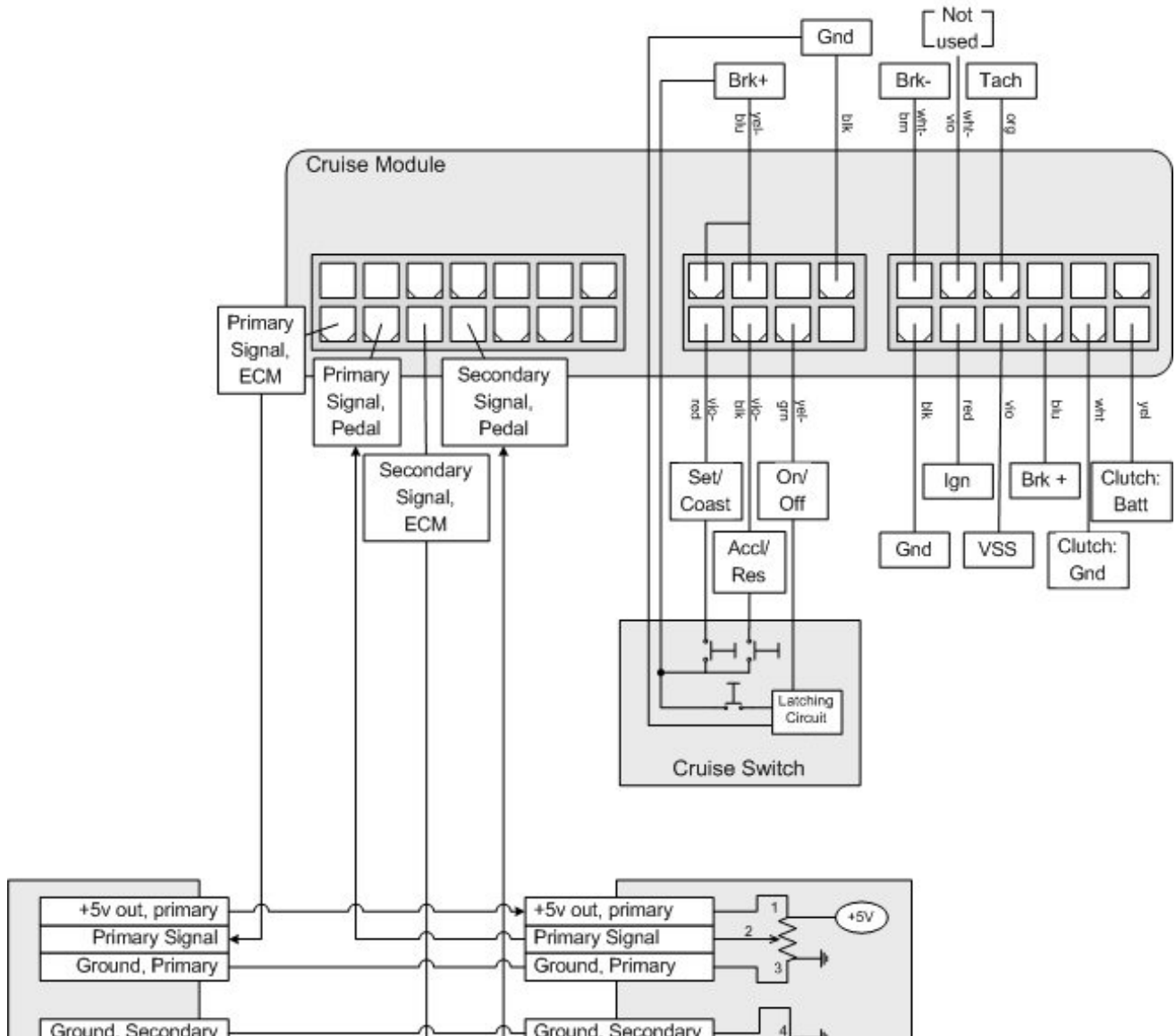

Posi-Tap™
TAP CONNECTOR



- TAPS WIRES WITHOUT CUTTING
- TOTAL WIRE INTEGRITY IS MAINTAINED
- INSTALLS IN SECONDS BY HAND
- NO CRIMPING OR TOOLS REQUIRED
- REUSABLE OR PERMANENT
- LESS RESISTANCE
- VIBRATION PROOF
- FULLY INSULATED

POWERS UP TO (4) LEADS AT ONCE!

QUICK & EASY

- 1** Insert Hot Wire
- 2** Tighten
- 3** Strip Leads
- 4** Insert & Tighten

NO CRIMPING

NO TOOLS NEEDED